

**EARTHQUAKE
HAZARD MITIGATION
HANDBOOK
FOR
PUBLIC FACILITIES**



**Produced By:
FEMA Region 10
Response & Recovery Division
Infrastructure Section**

February 28, 2002

**EARTHQUAKE
HAZARD MITIGATION
HANDBOOK**

FOR

PUBLIC FACILITIES

**Federal Emergency Management Agency
Region 10**

February 28, 2002

TABLE OF CONTENTS

Introduction

Purpose of Handbook

*Mitigation Alternatives for Earthquake Damaged
Public Facilities*

Earthquake Damage Introduction

I. BUILDINGS

A. Structural Building Elements.....	3
B. Non-Structural Building Elements.....	31
C. Building Utility Systems.....	47
D. Building Contents.....	59

II. BRIDGES

A. Pier Failure.....	67
B. Slab Failure.....	70
C. Span Failure.....	74
D. Cap Beam Failure.....	82

III. UTILITIES

A. Equipment Anchorage/Stability.....	88
B. Soil Movement/Settlement.....	91
C. Damage to Tank Structures.....	96

Appendices

A. Regulations & Considerations.....	i
B. Glossary & Keyword Index.....	iii
C. Acronyms.....	vii
D. References.....	viii
E. List of Contributors.....	xi

INTRODUCTION

The Federal Emergency Management Agency (FEMA) continuously strives to improve the delivery of disaster assistance to states and local governments. This *Earthquake Hazard Mitigation Handbook for Public Facilities* (Handbook) assists those entities directly affected by seismic events by suggesting various mitigation measures. These measures are intended to help identify options and provide mitigation ideas for local jurisdictions that can be used at any time, not only after a disaster.

FEMA is charged to provide the focal point of disaster response at the Federal level. FEMA's mission to reduce loss of life and property caused by natural disasters is accomplished through a comprehensive emergency management program.

Before a disaster strikes, FEMA provides funding and technical assistance for a range of preparedness and mitigation activities. One example has been Project Impact, which has helped build disaster-resistant communities, including the seismic retrofit of buildings in earthquake hazard zones.



During a disaster, FEMA works with governmental and volunteer agencies, such as the Red Cross, to meet the immediate needs of disaster victims by providing food, shelter, and medical care. Through the Federal Response Plan, FEMA coordinates the resources of other Federal agencies to respond to emergency situations that are beyond the capabilities of State and local resources.

After a disaster, FEMA coordinates long-term recovery efforts through a number of mitigation programs. The Public Assistance Program provides funding opportunities for implementing mitigation measures during the rebuilding of disaster-damaged public infrastructure after a disaster has been Presidentially-declared. The Hazard Mitigation Grant Program also supports a number of mitigation programs that protect communities by reducing or eliminating future disaster damage.

The Problem: As disasters have grown in frequency and severity, the costs of response and recovery have escalated to unsustainable levels. In the Pacific Northwest, between 1996 and 1998 alone, FEMA provided over \$535 million in disaster assistance. This figure does not include assistance paid by other Federal agencies, costs to State and local governments, or direct individual or business losses. Nationwide, natural disasters cost over \$50 billion each year.



The Solution: The most effective way to reduce these excessive losses is through disaster preparedness and mitigation. To best achieve this goal, we as a society need to vigorously pursue three objectives:

OBJECTIVE 1: To break the disaster–rebuild–disaster cycle. This cycle of repetitive loss is the historical mode of disaster recovery. But merely repairing substandard facilities to their pre-disaster condition does not protect the community from future disaster damages or reduce its long-term costs. Mitigation betterments should be considered in the rebuilding process, utilizing a multi-hazard approach wherever possible.

OBJECTIVE 2: To strengthen existing infrastructure and facilities to more effectively withstand the next disaster.

OBJECTIVE 3: To ensure that communities address natural hazards. Comprehensive plans should acknowledge all hazards that pose a risk and take steps to avoid these hazards altogether, or incrementally reduce the community’s exposure to its hazards.

The Savings: The outcome of achieving these objectives will be more resilient and economically sustainable communities. For every dollar spent in damage prevention in the Pacific Northwest, two to three dollars are saved in future repairs.

PURPOSE OF HANDBOOK

The *Earthquake Hazard Mitigation Handbook for Public Facilities* (Handbook) is intended to aid local jurisdictions in identifying a variety of feasible mitigation measures that can be implemented during the rebuilding process. The Handbook focuses on projects commonly eligible for hazard mitigation funding under the Public Assistance Program. Frequently, due to the urgency to repair the facility, long-term mitigation opportunities are not fully explored. As a result, Hazard Mitigation funding opportunities through FEMA’s Public Assistance program are not fully utilized.

This Handbook provides local jurisdictions with mitigation ideas, many of which have demonstrated success and timeliness. These mitigation measures should be used as a source of ideas for potential mitigation projects, regardless of whether it will receive FEMA funding.

In addition to the ideas in this Handbook, FEMA’s Mitigation Policy No. 9526.1 can be referenced. This Policy includes an appendix of measures already determined by FEMA to be eligible and cost-effective. However, none of the mitigation measures in this Handbook should be considered ‘pre-approved’ or automatically eligible for FEMA funding.

MITIGATION ALTERNATIVES FOR EARTHQUAKE DAMAGED PUBLIC FACILITIES

Organization of mitigation measures in this Handbook: Damages to public facilities sustained in an earthquake can vary greatly depending upon the various failures or damages that occur. This Handbook is organized first by type of facility, then by damages that are commonly sustained by that facility. Each category of damage lists a selection of mitigation ideas to consider. The general effectiveness, limitations, and considerations of each mitigation measure are also identified.

Engineering, design, and permitting requirements:

The Handbook does not detail site-specific requirements, as the engineering analysis, design, and permitting of each project will vary widely. Repair and mitigation of structural elements most often will require a professional engineer who can provide a detailed analysis of the structure's seismic behavior to determine the appropriate repair and mitigation.

Public Assistance eligibility:

As with all agencies that provide federal funding, FEMA requires specific criteria be met regarding eligibility before it approves proposed projects. **ONLY FEMA CAN DETERMINE THE ELIGIBILITY OF AN APPLICANT, THE FACILITY, THE WORK, OR THE COST.** Eligibility criteria are detailed in the *Public Assistance Guide*, Publication No. FEMA 322. Additional information can also be obtained through FEMA's website at www.fema.gov or the FEMA Regional Office.

Regulations & Considerations:

The following considerations have been symbolized for their reference in each mitigation measure, and are defined in Appendix A, "Regulations and Considerations."



National Environmental Policy Act



National Historic Preservation Act



Maintenance Required to Maintain Effectiveness



Project May be Cost-Prohibitive



Professional Engineer Required for Design



Structure's Aesthetics Could be Impacted

Mitigation Keywords:

The "Glossary and Keyword Index," found at Appendix B, provides a glossary of terms used in the Handbook and identifies mitigation keywords, which are italicized and bolded in the text. A keyword is a mitigation element used in two or more mitigation measures in the Handbook, and is intended to help the reader become familiar with the mitigation element by understanding its use in a different measure.

EARTHQUAKE DAMAGE INTRODUCTION

Earthquakes can be one of the most devastating natural disasters. In September, 2000, FEMA released a study estimating annual earthquake losses in the United States to be \$4.4 billion, with California, Oregon and Washington accounting for \$3.3 billion. Since 1993, FEMA's Region 10 has been granted 3 Presidentially-declared earthquake disasters. The most recent of which occurred near Olympia, Washington on February 28, 2001. The recovery of this "Nisqually Earthquake" continues as of this writing, with an initial preliminary damage assessment of \$204 million in damages to public facilities. The largest earthquake in the United States also occurred within Region 10's jurisdiction. The 1964 Alaska Earthquake, with a 9.2 magnitude, caused \$311 million in damage (in 1964 dollars) and killed 115 people. Nationwide, 39 states are at high risk for a devastating earthquake.

Earthquake mitigation, ranging from upgraded building codes to homeowner education to retrofitting bridges and other lifelines, has had tremendous success in reducing earthquake damage. One effective earthquake mitigation is upgrading building codes and standards. As a result of the Northridge Earthquake of 1994, in southern California, for example, the greatest physical loss was sustained by older buildings – over 112,000 were damaged. However, according to a 2000 report



on hazard mitigation, those structures built after 1976 performed significantly better than those built prior to 1976, when building codes were upgraded to include seismic performance and resistance.

By far the most common type of earthquake damage is structural, which can be hidden or apparent, and can be cosmetic or can compromise the structural integrity of the building. Non-structural building damage might include impacts to sprinklers, pipes, suspended ceilings, etc.

This Handbook identifies the types of earthquake damage most typically sustained by the following public facilities:

- Buildings..... p. 1
- Bridges..... p. 65
- Utilities..... p. 85

BUILDINGS

Introduction

Buildings are the most commonly damaged public facility in an earthquake. In the Nisqually Earthquake three-fourths of all damages were to buildings.

This section provides mitigation measures for many building damages. A building's repair needs and appropriate retrofits are dependent upon numerous factors such as the structure type and design. Determining the most appropriate seismic retrofit for a building commonly requires an engineer.

Typical Damages for Building Types

Wood Frame Structures. Well designed wood structures have generally performed well in earthquakes. Failures are often due to lack of foundation anchorage or unbraced crawlspace (cripple) walls.

Tilt-up Structures. Tilt-up construction usually involves casting concrete walls at the site and "tilting" them into place. The most common failure is wall-roof separation resulting from inadequate ties. Other problems are weak connections between individual wall panels, failure of diaphragms and exterior elements, and failure in panels with large openings.

Concrete Structures. Concrete structures may be cast-in-place and/or precast. Cast-in-place concrete buildings can be damaged or collapse, particularly at the piers, beams, and construction joints. Precast structures can experience damage in joints and connections.

Steel Frame Structures. These structures generally perform better than other structure types. Steel moment frame structures may have damage to primary members, distress at moment connections, movement between floor levels (story drift), and may sustain broken or buckled braces and connections.

Masonry Structures. There are two kinds of masonry construction: unreinforced and reinforced. Unreinforced masonry structures, particularly bearing walls, are the form of construction most vulnerable to earthquake damages. Floors and walls of these structures are often not tied together or, when tied together, are only weakly connected. Some older

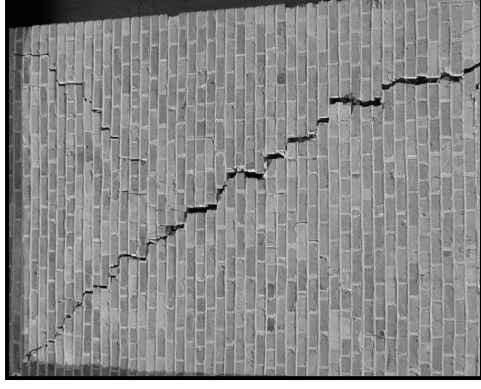

structures have mortar that has deteriorated. Long, unreinforced masonry wall sections are particularly prone to severe cracking or failure due to the lack of bracing or reinforcing steel. Chimneys in older buildings are commonly damaged or destroyed, creating falling hazards.

The appropriate retrofitting for a building should only be done by a qualified engineer. Measures included in this Handbook are generalized for purposes of suggesting mitigation ideas to be reviewed by qualified engineers. In fact, the wrong retrofit for a building type can be more dangerous than nothing at all.

This section discusses mitigation from common earthquake damages to building and is organized by:

- A. *Structural Building Elements*.....p. 3
- B. *Non-Structural Building Elements*.....p. 31
- C. *Building Utility Systems*.....p. 47
- D. *Building Contents*.....p. 59

A. Structural Building Elements

Introduction

The structural elements of a building comprise the 'skeleton' that supports the rest of the building, including the foundation, load-bearing walls, beams, columns, floor system and roof system, as well as the connections between these elements (Figure 1). When loads are applied to a building, elements and connections can experience tension, compression, shear, bending, and torsion (Figure 2). Most buildings are primarily designed to resist vertical forces from gravity. The roof and floor systems carry these vertical forces to the supporting beams. The beams carry the forces to the columns and bearing walls, which then carry the forces down to the foundation and the supporting soil. This process of carrying forces from the roof down to the soil is known as a load path. The failure of any

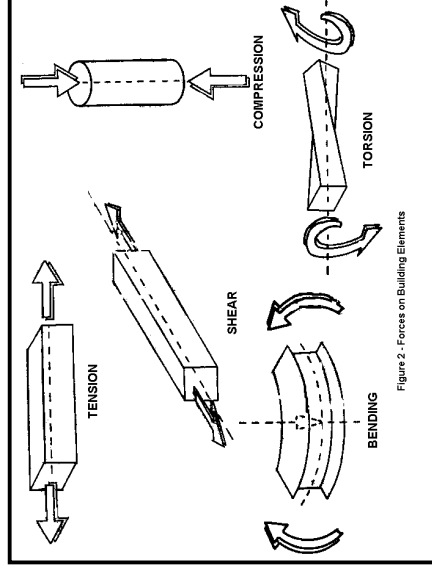
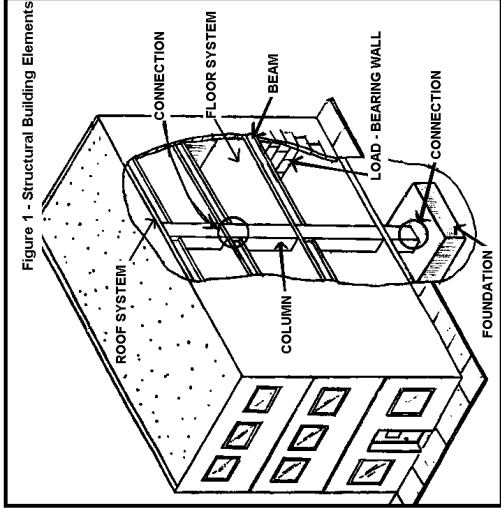

Figure 2 - Forces on Building Elements

building element or connection along the load path can lead to building damage or collapse.

Earthquake forces can act in all directions. Unlike gravity loads that are transferred in a downward direction, earthquake loads start at the supporting soil and must be carried by the building. The horizontal and vertical earthquake forces travel in different load paths and may result in tension, shear compression, bending or torsion forces.

How a building performs in an earthquake depends upon a few key building characteristics:

Ductility. Under normal conditions, a building experiences elastic deformations, deforming as force is applied and returning to its original shape when removed. However, extreme earthquake forces may generate inelastic deformations in which the element does not return to its original shape after the force is removed. Ductility is the property of certain materials which absorbs inelastic deformation before failing. Building elements constructed with ductile materials have a "reserve capacity" to resist overloads generated by earthquakes. Therefore, buildings constructed of ductile materials, such as steel and adequately reinforced concrete, tend to withstand earthquakes much better than those constructed of brittle materials such as unreinforced masonry.

Strength and Stiffness. Strength is the property of a material to resist force. Stiffness is the property of a material to resist displacement. When two elements of different stiffnesses are forced to deflect the same amount, the stiffer element will carry more of the load because it takes more force to deflect it. When stiff concrete and masonry elements are tied to more flexible steel or wood elements, the concrete and masonry takes more of the load for the buildings

Bracing/Seismic Resistant Components. Four basic components provide seismic resistance against lateral forces (Figure 3):

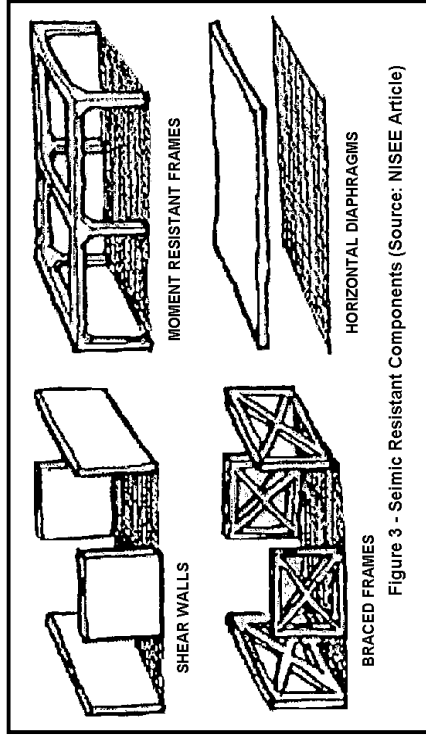

Figure 3 - Seismic Resistant Components (Source: NISEE Article)

- **Shear walls** are large structural walls placed in a building that carry forces from the roof and floor systems across the building, down to the supporting foundation, and into the soils.
- **Braced frames** consist of beams and columns with stiff diagonal braces, performing like shear walls, but using less material.
- **Moment resistant frames** (generally steel/moment frames) consist of steel beams welded to one or more columns to carry multi-dimensional earthquake forces.
- **Horizontal Diaphragms** are floor and roof deck systems that carry lateral forces across the building to shear walls, braced frames, and/or columns.

Connections. Strong building connections allow forces and displacements to be transferred between vertical and horizontal building elements. In addition, strong connections increase the overall structural building strength and stiffness by allowing all of the building elements to act together as a unit. Inadequate connections represent a weak link in the load path of the building and are a common cause of earthquake building damage and collapse.

Damping. When a tuning fork strikes a surface, it vibrates back and forth at a certain rate – this rate is known as its fundamental period. All objects, including buildings, have their own unique fundamental period of vibration. Ground shaking from an earthquake will cause vibrations in a building. If the

level of ground shaking matches the fundamental period of the building, it will cause the level of building vibrations to greatly increase, or resonate, which can lead to building damage or collapse. Damping devices reduce these vibrations and avoid resonance and subsequent damage.

Weight Distribution. Buildings that are wide at their base and have most of their weight distributed to their lowest floors generally fare better in earthquakes than taller ones. Tall, top-heavy buildings can act like an inverted pendulum, and experience greater displacements than those shorter and heavier near the base.

Building Configuration. Square or rectangular buildings with simple floor plans tend to perform better in earthquakes than buildings composed of irregular shapes or ‘open’ floor plans with large windows, foyers or lobbies that create a soft story condition. Buildings with irregular shapes cannot distribute lateral forces evenly back and forth, creating torsion and other additional forces that can increase damage at key points in the building.

Foundation Soil Characteristics. Buildings can be severely damaged when the soils that support the building foundations shift, sink, slide, or liquefy. Optimally, structures should not be located in such areas.

The appropriate structural retrofitting should be done only by a qualified engineer. Measures in this Handbook are generalized for purposes of suggesting mitigation ideas to be reviewed by qualified engineers. In fact, the wrong retrofit for a building type can be more dangerous than nothing at all.

Structural-related damage to buildings due to earthquakes may be caused by:

1. Deficient Wall Bracing	p. 7
2. Weak Floor/Roof Systems	p. 13
3. Weak Connections	p. 16
4. Soft Story Condition	p. 20
5. Lack of Reinforcement/Confinement	p. 23
6. Poor Seismic Response	p. 27

A.1 Deficient Wall Bracing

Problem: Many load-bearing walls, particularly long walls constructed of unreinforced masonry, do not have enough lateral bracing to carry earthquake forces that are perpendicular to the walls. As a result, these walls may suffer damage or failure during an earthquake, causing partial or even total building collapse.

Mitigation Objective: Reduce damage to walls by strengthening, reinforcing, or protecting to withstand forces perpendicular to the wall.

Mitigation measures to reduce building damage caused by insufficiently braced walls include:

- a. Reinforce Building Using Shear Walls p. 8
- b. Brace Long Walls With Crosswalls p. 9
- c. Brace Cripple Walls p. 10
- d. Reinforce Building With Cross Bracing p. 11
- e. Protect Walls by Stiffening Floors p. 12

A.1.a Reinforce Building Using Shear Walls

While **crosswalls** limit the movement of walls and absorb energy, shear walls limit stresses in walls and absorb force. In some cases, an existing interior wall can be modified to act as a shear wall or be used as a form for a **shotcrete** shear wall.

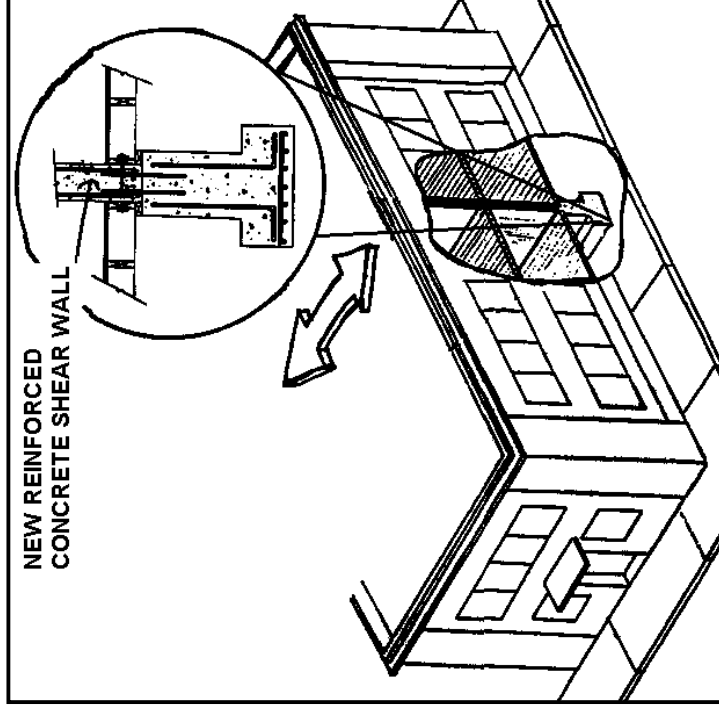

Effectiveness:

- Very effective for increasing earthquake resistance and reducing damage.

Limitations:

- A new shear wall should be supported on a new reinforced concrete footing and **anchored to the sill plate**.

Considerations:



A.1.b Brace Long Walls With Crosswalls

Long wall sections bend more than shorter walls, making them more vulnerable to earthquake damage. **Crosswalls** can be added to act as dampers, absorbing energy and limiting displacements from ground motion.

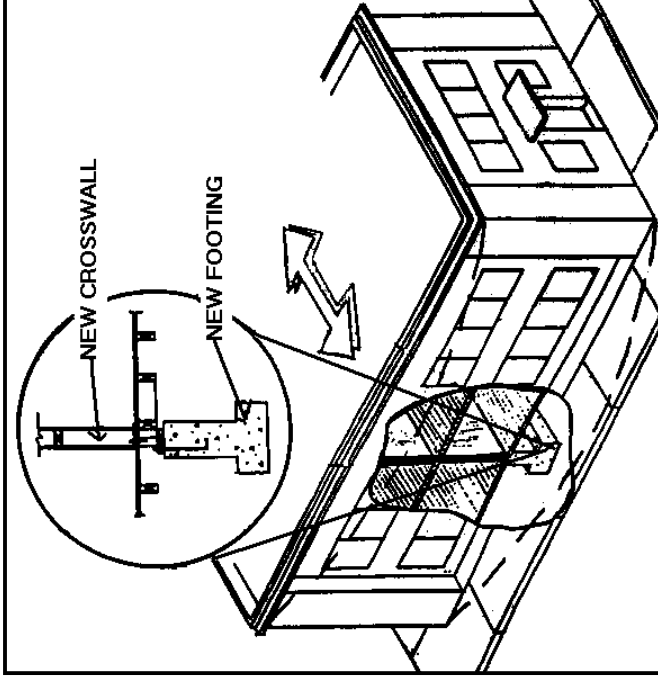

Effectiveness:

- Somewhat to very effective, depending on pre-disaster building condition.

Limitations:

- Crosswalls should be tied to the roof framing as well as the floor system to reduce the risk of parapet failure and damage to the upper walls.
- Crosswalls should be **anchored with the sill plate** and bolted to a new, reinforced concrete footing.

Considerations:



A.1.c Brace Cripple Walls

If a cripple wall is not braced adequately, it can shift during an earthquake. To brace a cripple wall, add horizontal or diagonal blocking between the vertical studs at the top and bottom of the cripple wall. Plywood can also be **anchored** to the interior face of the cripple wall, as well as **to the sill plate** below the foundation to increase its strength.

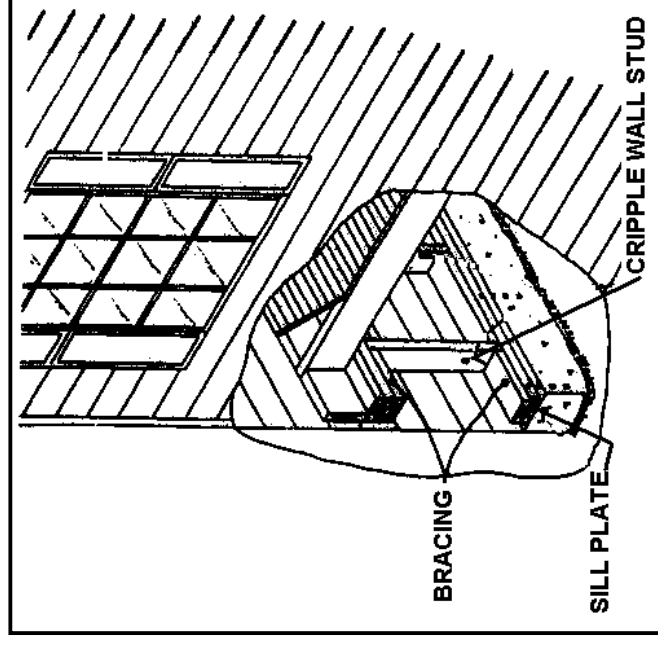

Effectiveness:

- Somewhat effective.

Limitations:

- Confinement in the crawl space may limit ability to perform this mitigation.

A.1.d Reinforce Building With Cross Bracing

Full-height, steel **cross bracing** can increase a building's capacity to withstand seismic forces. Cross bracing can be exterior or interior and is secured to the building at floor level.

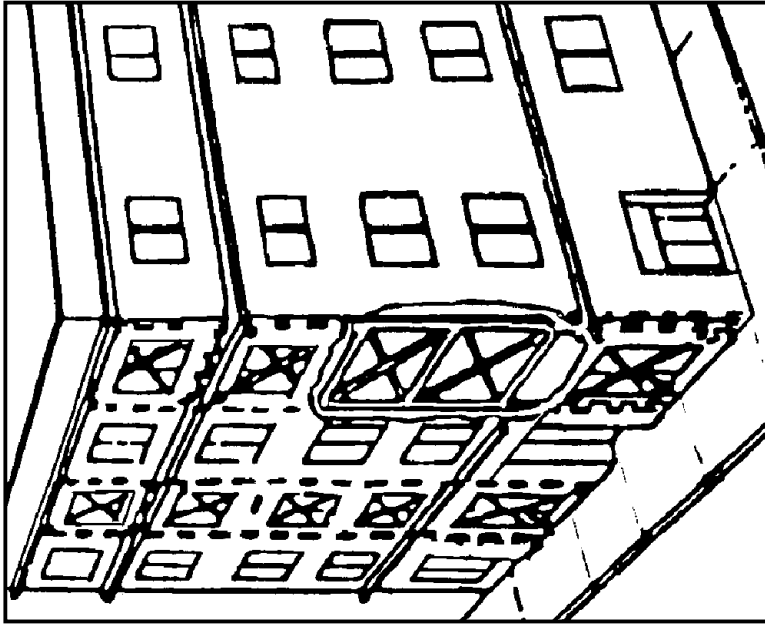

Effectiveness:

- Somewhat to very effective, depending on pre-disaster building condition and the extent of cross bracing.
- Increase effectiveness by tying exterior walls to the floors.

Limitations:

- Foundation must be able to support bracing.
- Multi-story cross bracing is less effective than cross bracing at each floor level.

Considerations:



A.1.e Protect Walls by Stiffening Floors

Earthquake movement of floor systems may damage unreinforced masonry walls. Stiffening the floors by adding new plywood sheathing on top of the existing sheathing will reduce wall damage. A similar technique can be used for strengthening precast concrete floor diaphragms by placing a continuous layer of cast-in-place and steel-reinforced concrete on top of the existing floor.

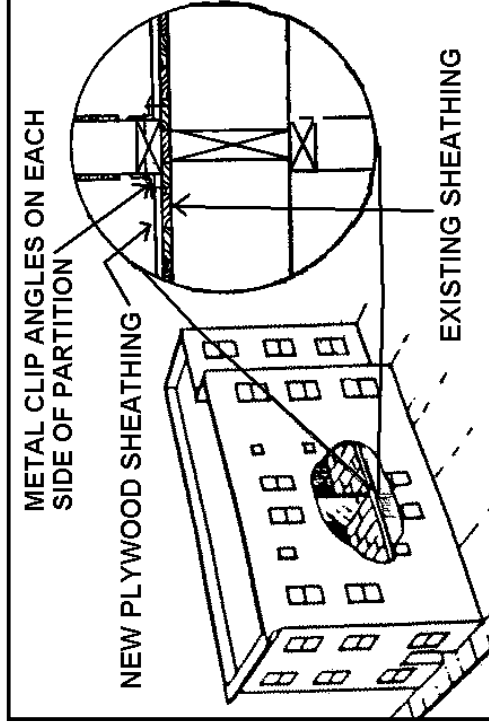

Effectiveness:

- Somewhat to very effective, depending on pre-disaster building condition.
- Adding **tenstion ties** and **shear anchors** to tie the floor system to the walls can increase effectiveness.

Limitations:

- If interior wall partitions cannot be removed, metal clips along the base will allow the transfer of forces across the bottom plate of the partition.

Considerations:



A.2 Weak Floor/Roof Systems

Problem: Many floor and/or roof systems are not strong enough to carry lateral earthquake forces. As a result, floors and roofs may suffer localized damage or buckle during an earthquake. Irregular floor plans that cannot evenly distribute forces to floor or roof members exacerbate this problem.

Mitigation Objective: Strengthen weak floor and/or roof systems by adding components that resist lateral earthquake forces.

Mitigation measures to reduce building damage caused by weak floor and/or roof systems include:

- a. Strengthen Floor/Roof Systems With Steel Chords p. 14
- b. Add Collectors to Strengthen Floors/Roofs..... p. 15

A.2.a Strengthen Floor/Roof Systems With Steel Chords

Long masonry walls tend to crack and collapse due to bending. Damage may be reduced by securing the long walls to both the floor and roof by using either chords composed of steel straps or continuous steel angles. The straps or angles allow the walls and the floor and roof to act like a steel I-beam, increasing the strength of the floor, the roof, and the building.

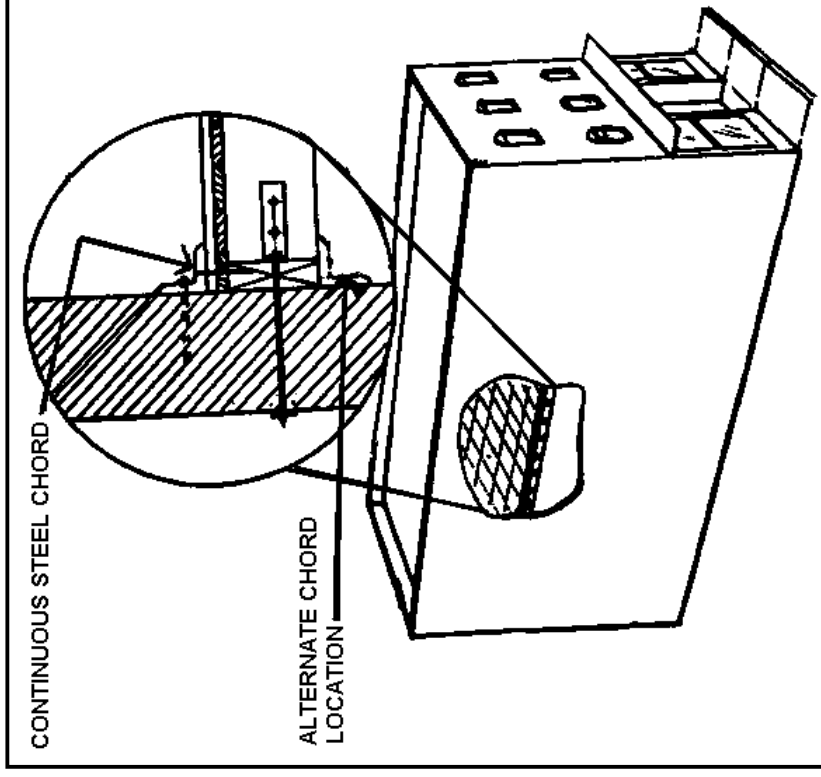

Effectiveness:

- Very effective.
- Add *tension ties* and *shear anchors* to increase effectiveness.

Considerations:



A.2.b Add Collectors to Strengthen Floors/Roofs

Buildings may be damaged if floor and/or roof systems cannot transfer shear forces. Collectors, or drag struts, collect or 'drag' shear forces from unsupported areas of the floor or roof systems to the load-bearing walls. A collector is composed of a long wood or steel member that extends into the floor or roof framing at one end and is anchored to load-bearing walls at the other end.

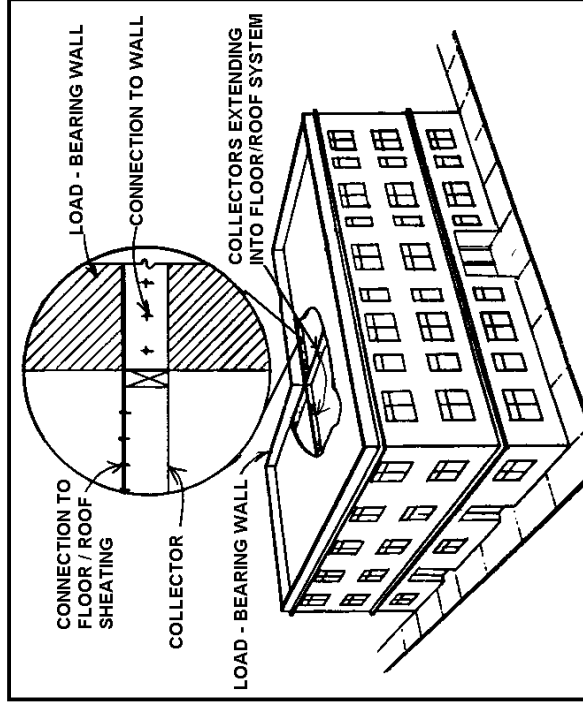

Effectiveness:

- Somewhat to very effective.

Limitations:

- Effectiveness limited by the strength and configuration of the building.

Considerations:



A.3 Weak Connections

Problem: Key connections between structural building elements may not be sufficient to carry earthquake forces and movements. These weak connections are vulnerable to damage or failure during an earthquake.

Mitigation Objective: Strengthen weak connections to allow building elements to work as a single unit to resist earthquake forces and movements.

Mitigation measures to reduce building damage caused by weak connections include:

- Anchor Sill Plate to Foundation p. 17
- Install Tension Ties Between Elements p. 18
- Install Shear Anchors..... p. 19

A.3.a Anchor Sill Plate to Foundation

During an earthquake, a building can shift on the foundation if its **sill plate** is not **anchored** to the foundation. Sill plates should be bolted or otherwise anchored to the building foundation. Bolts long enough to pass through the sill plate and penetrate several inches into the foundation should be installed every few feet along the exterior walls.

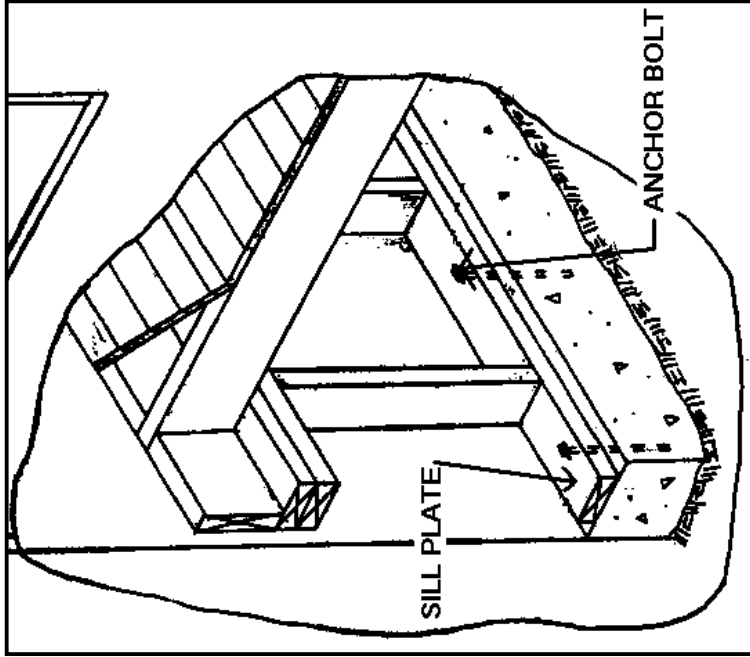

Effectiveness:

- Very effective.
- Bracing cripple walls can increase effectiveness.

Limitations:

- May require that portions of the walls or floor be temporarily cut away.

A.3.b Install Tension Ties Between Elements

During an earthquake, many unreinforced masonry and wood buildings suffer damage or even collapse due to inadequate connections between the walls and the roof/floor systems.

Tying the walls to the roof and floor systems using **tension ties** can strengthen these buildings. Tension ties limit wall deflections by tying them to the floor system, thereby reducing the likelihood of damage or building failure.

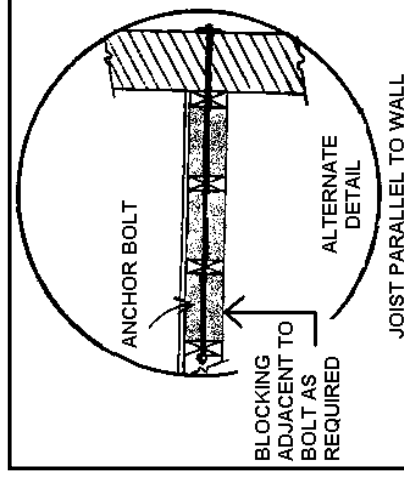
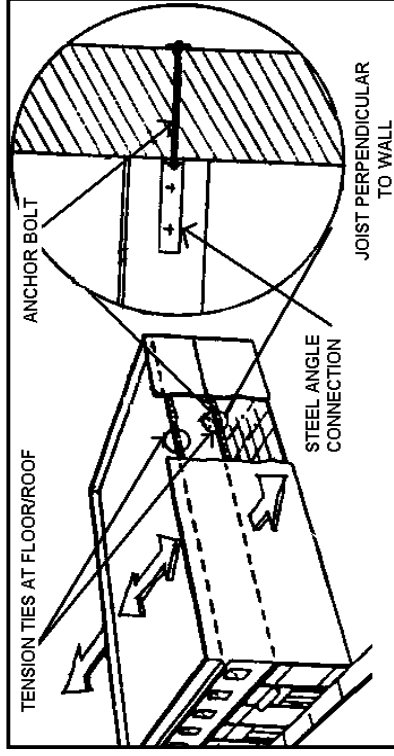

Effectiveness:

- Very effective.
- Consider adding **shear anchors** to the walls to increase effectiveness.

Considerations:



A.3.c Install Shear Anchors

Earthquakes commonly damage unreinforced masonry buildings due to sliding between the walls, and the floor and roof systems. Installing **shear anchors** between the walls, and the roof and floor systems, prevents sliding between the walls and floors. A typical shear anchor is connected through the floor joists using a steel plate on one end, while the other end is secured into the wall using drypack or epoxy grout.

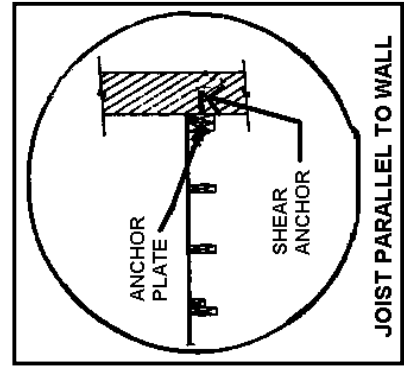
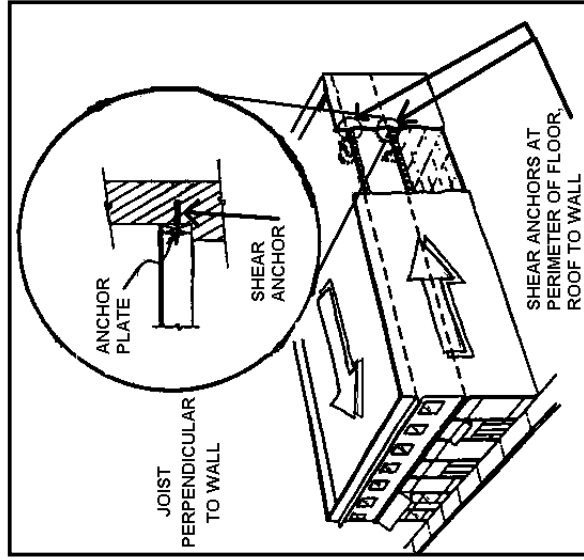

Effectiveness:

- Very effective.
- Consider adding **tension ties** to the walls to increase effectiveness.

Considerations:



A.4 Soft Story Condition

Problem: A soft story condition occurs where the lowest floor of a building contains large open spaces, such as for parking or interior design purposes, and is used to support one or more heavier upper floors. The lowest floor, or soft story, is vulnerable to damage or collapse from lateral earthquake forces.

Mitigation Objective: Strengthen soft stories by adding components that resist lateral earthquake forces and displacements.

Mitigation measures to reduce building damage from soft story conditions include:

- Increase Lateral Support by Infilling Openings p. 21
- Reinforce Building With Steel Moment Frames p. 22
- Reinforce Building Using Shear Walls See below
- Reinforce Building With Cross Bracing See below

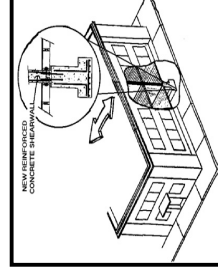

c. Reinforce Building Using Shear Walls (p. 8)

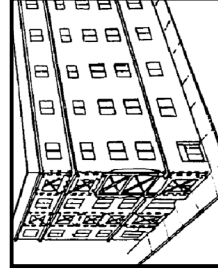

d. Reinforce Building With Cross Bracing (p. 11)

A.4.a Increase Lateral Support by Infilling Openings

Soft story conditions often cannot sustain the forces of a major seismic event. Enclosing or infilling the openings increases seismic strength and reduces the stresses on the walls. Windows and door openings are filled with reinforced concrete or reinforced masonry, which is connected to the existing wall using steel dowels.

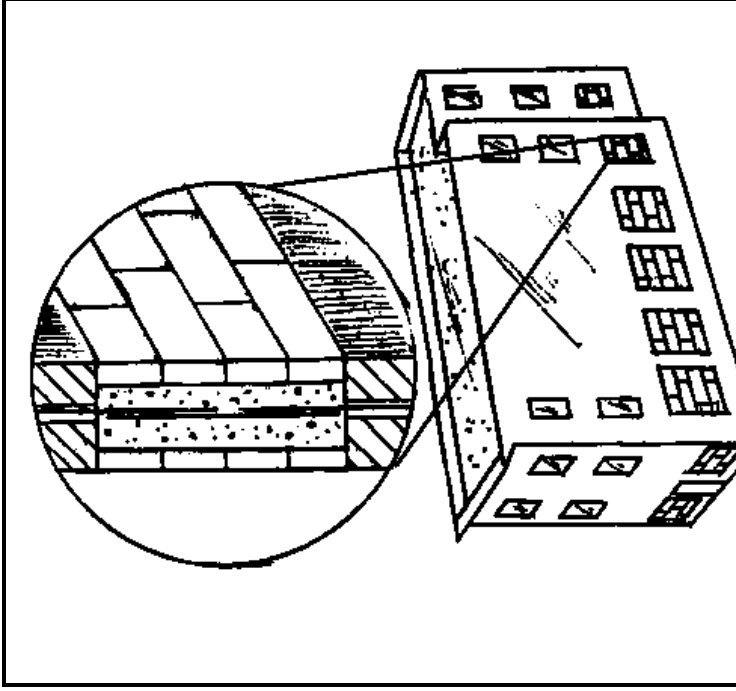

Effectiveness:

- Very effective.

Limitations:

- May have significant impact on form and function of the building.

Considerations:



A.4.b Reinforce Building With Steel Moment Frames

Lateral bracing can be employed through the use of a steel moment frame which allows the open space to be maintained and eliminates the need for infilling openings or additional **crosswalls**. A steel moment frame is composed of beams and columns welded at their joints and connected to the floor above the open area.

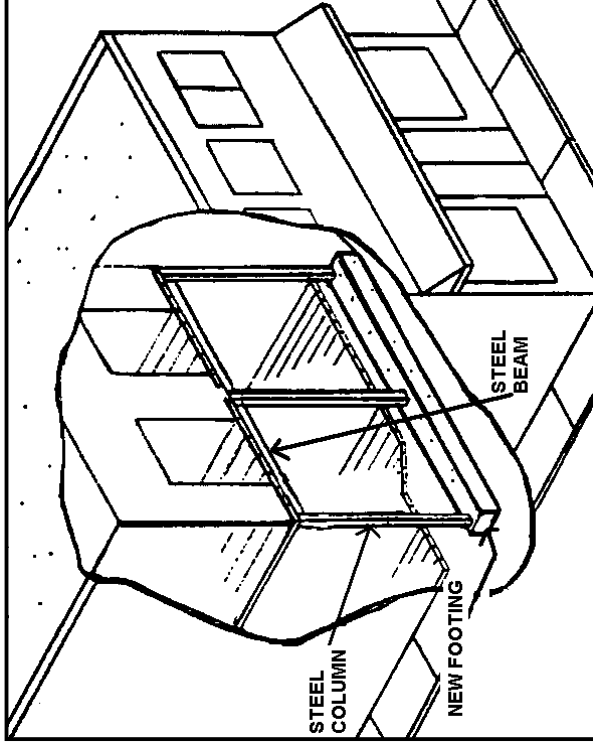

Effectiveness:

- Very effective.
- Consider crosswalls for maximum effectiveness.

Limitations:

- Steel moment frame must be adequately connected to the new footing and to the structure.
- Field welding of the frame components is necessary and a new footing for the frame must be added.

Considerations:



A.5 Lack of Reinforcement/Confinement

Problem: Many concrete or masonry load-bearing walls do not have enough steel reinforcement to carry earthquake forces and movements that are parallel to the walls, or do not have sufficient confinement to prevent buckling of the reinforcing steel inside the column. These deficiencies may result in partial or total building collapse.

Mitigation Objective: Reinforce walls and/or confine columns that are at risk so they can withstand earthquake forces and movements.

Mitigation measures to reduce building damage from inadequate reinforcement or confinement include:

- a. Reinforce Walls With Fiber Materials p. 24
- b. Reinforce Walls With Shotcrete p. 25
- c. Confine Columns With Fiber Wraps p. 26

A.5.a Reinforce Walls With Fiber Materials

Earthquake forces may cause extensive crack damage in unreinforced masonry bearing walls which can weaken the building. Walls can be strengthened in-place using fiberglass or **carbon fiber sheets**. The fiber sheeting is secured to the exterior walls using a chemical adhesive and protected with a weather-resistant barrier or other exterior finish.

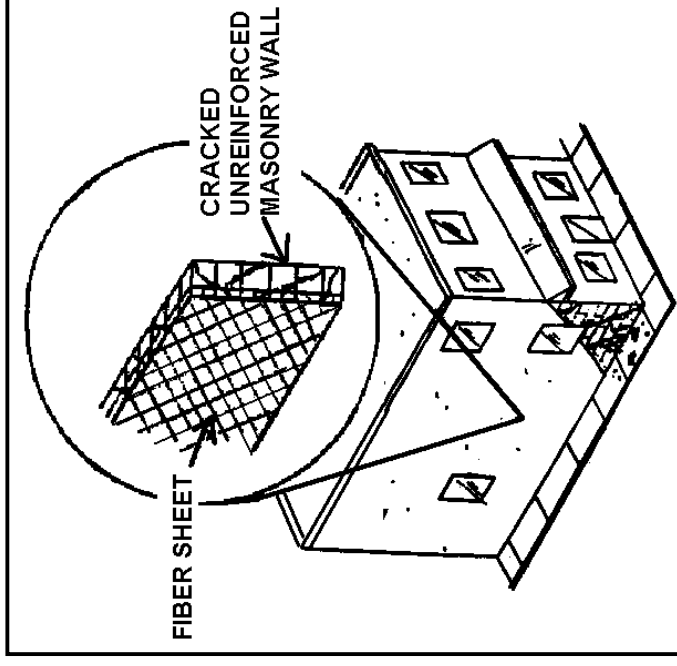

Effectiveness:

- Very effective for cracks which threaten structural integrity.
- Place sheeting on both sides of the walls to increase effectiveness.

Limitations:

- The wall may not be returned to pre-disaster strength if cracking is too severe.

Considerations:



BUILDINGS

A.5.b Reinforce Walls With Shotcrete

Unreinforced masonry walls can be strengthened in-place using **shotcrete**, also known as gunite, which is concrete sprayed in place. Shotcrete is applied directly to the existing walls and secured using epoxy anchors. Shotcrete is reinforced with steel and supported by either a new foundation or by underpinning and enlarging the wall foundation.

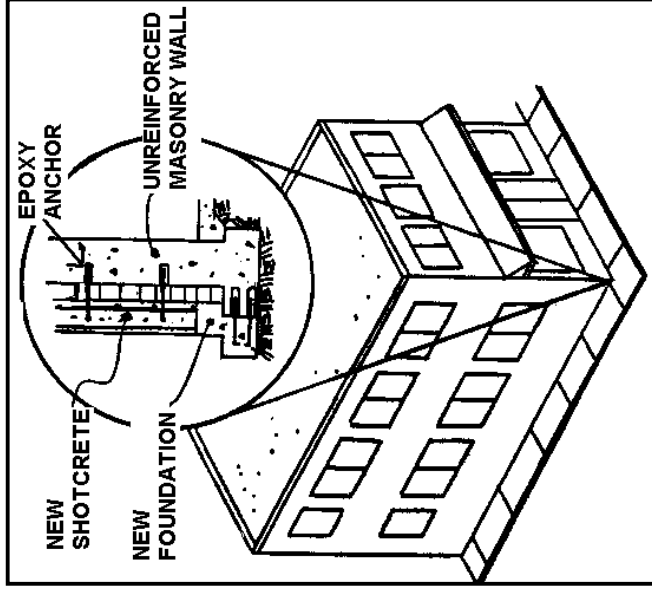

Effectiveness:

- Very effective. Strength of shotcrete varies with thickness.

Limitations:

- Unreinforced materials covered by shotcrete are still subject to future cracking or spalling.

Considerations:



A.5.c Confine Columns With Fiber Wraps

Earthquake forces can buckle reinforced steel within concrete and masonry columns. A fiberglass or **carbon fiber wrap** around columns will strengthen them and may prevent such failures. The high strength of the fiber wrap confines reinforcing steel in the column and significantly increases the ultimate strength of the column.

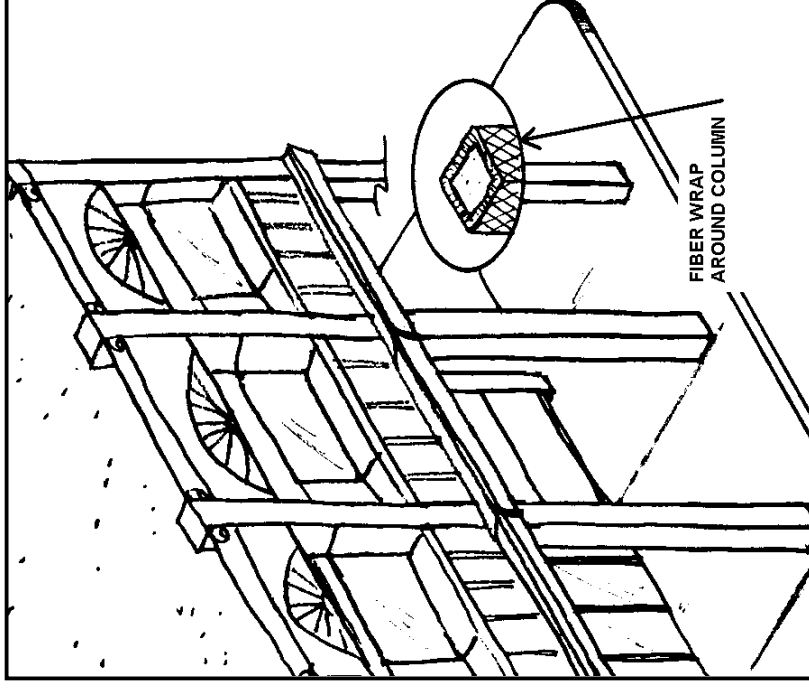

Effectiveness:

- Very effective.

Considerations:



A.6 Poor Seismic Response

Problem: Some buildings exhibit poor seismic behavior characteristics that are difficult to correct by mitigation of individual elements or connections alone. The fundamental period of certain buildings may make them highly susceptible to resonance with ground shaking during an earthquake. Other buildings may be composed of two or more different structures that may behave very differently and damage each other during an earthquake.

Mitigation Objective: Improve behavior of buildings with poor seismic characteristics.

Mitigation measures to reduce building damage caused by poor response to seismic forces include:

- a. Isolate Building With Vibration Isolation Bearings p. 28
- b. Install Dampers p. 29
- c. Create Separation Joints Between Structures..... p. 30

A.6.a Isolate Building With Vibration Isolation Bearings

Rigid and brittle buildings can suffer extensive earthquake damage. This damage can be greatly reduced by **isolation bearings**. Vibration isolation bearings are designed to dampen earthquake ground movements before they reach the building and help the building move as a unit.

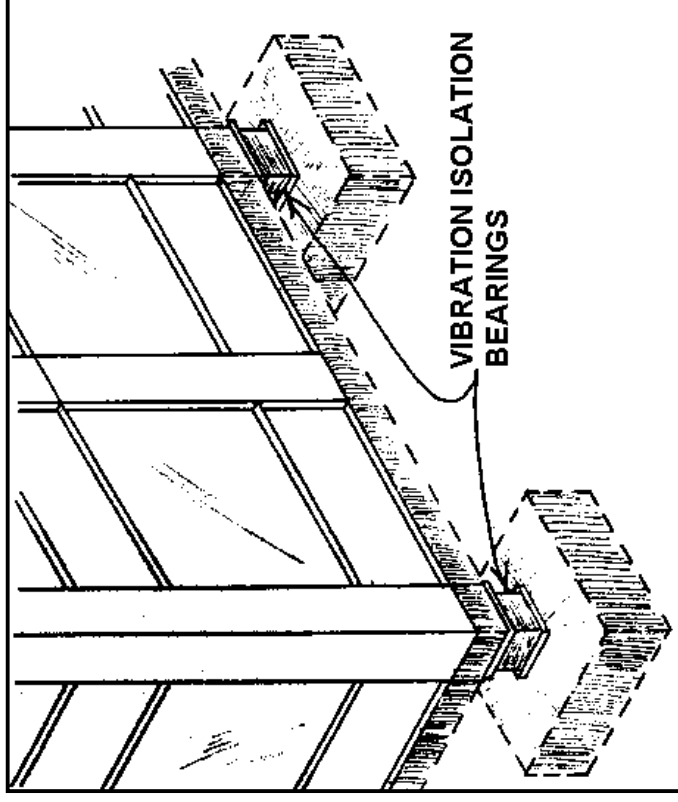

Effectiveness:

- Very effective when properly installed.

Considerations:



A.6.b Install Dampers

Dampers can be installed to help absorb movement and increase a building's earthquake resistance. The dampers act similar to automobile shock absorbers and can be integrated into **cross bracing** throughout the building frame.

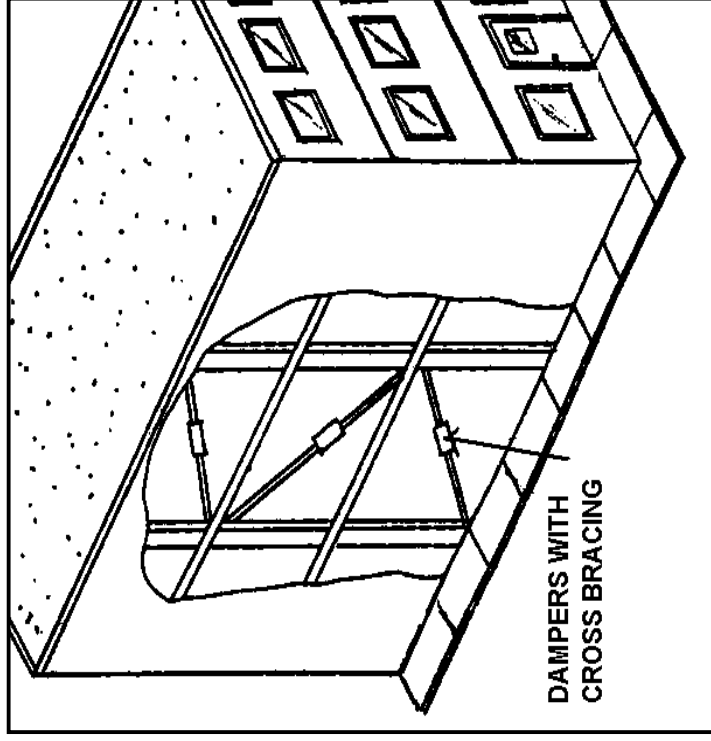

Effectiveness:

- Somewhat to very effective.

Limitations:

- Effectiveness depends on existing building behavior and location of dampers.

Considerations:



A.6.c Create Separation Joints Between Structures

Sometimes different structures are combined within (or immediately adjacent to) one building. For example, a tall, unreinforced masonry structure may be combined with a low-rise, modern, steel-framed addition. These two structures will behave very differently in an earthquake, which can lead to the transfer of damaging impact forces between the two structures and cause either damage or collapse.

Separation joints allow each structure to behave independently and avoid impacts from the other structure. Exterior joints between the two structures should be filled with elastic materials and then weatherproofed. All separation joints should be wide enough to accommodate differences in lateral movement between the two structures.

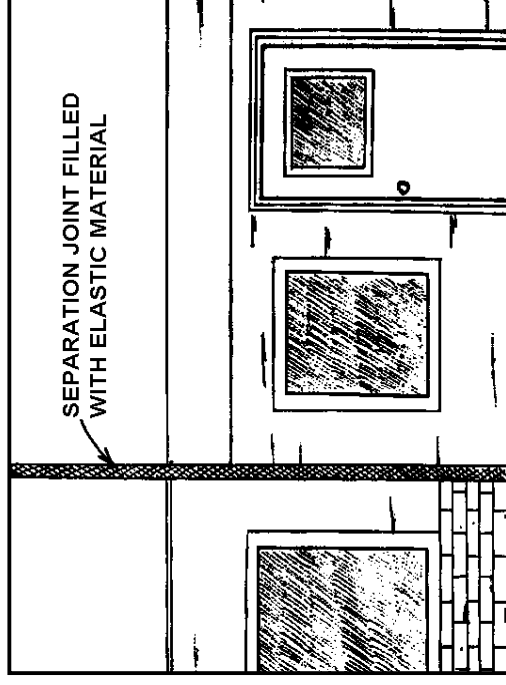

Effectiveness:

- Very effective at the site of the separation joints.

Limitations:

- Difficult for shared joists and columns.
- The seismic strength of the structures is not increased by the separation joints.

Considerations:

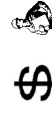

B. Non-Structural Building Elements

Introduction

Non-structural elements of a building are those elements that will not cause a building to collapse if they fail, such as parapets, chimneys, exterior facing, windows, doors, partition walls, suspended ceilings, etc. These elements are generally composed of weak, brittle materials such as glass, unreinforced masonry, or stone.

Non-structural elements of a building are most likely to be damaged as a result of an earthquake for two primary reasons:

1. Non-structural elements are often poorly anchored to the structural elements of the building.
2. Connections are not strong enough to carry the large lateral forces associated with earthquakes.

Types of non-structural building damage. Typical types of non-structural earthquake damage are described below:

Parapets. Brick parapets are typically mounted along the tops of unreinforced masonry buildings. Parapets are heavy, brittle, and typically collapse near the centers of long walls or at corners.

Architectural Elements. Cornices, corbels, and other architectural elements are common among historic, unreinforced masonry structures. Such elements are generally constructed of stone or other heavy, brittle materials and often fail due to poor anchorage or bracing.

Chimneys. Brick chimneys are heavy, brittle, and can fail unless reinforced near the top and supported by the building roof and walls.

Stone Facing or Wall Panels. Stone facing and precast concrete wall panels typically fail where anchorage is poor or at sections of the building that experience large deflections.

Windows. Glass windows typically crack or shatter when the frames are distorted or damaged.

Suspended Ceilings and Fixtures. Suspended ceilings and overhead lighting fixtures typically fail where anchorage is poor, or the runners that support the panels and lights are too weak to withstand lateral earthquake forces.

Interior Partitions. Interior partitions of all types and ages of buildings are often made of materials that fail when not secured to the floor or roof system. Partitions in older buildings may be constructed of heavy, brittle materials and can topple unless they are braced against the floor or roof of the building.

Raised Computer Floors. Raised floors that support computer equipment are found in many buildings. These floors and the equipment they support can be damaged or destroyed due to inadequate anchorage to the structural floor.

Since non-structural elements are supported by structural elements, a structural engineer may need to be consulted to identify whether certain mitigation measures are appropriate for a given building. Some non-structural measures are included in this section and are not appropriate for all buildings. **Be aware** that choosing the wrong measure may cause more problems than not doing any retrofit at all.

This section will discuss mitigation measures to protect non-structural building elements from damage caused by:

1. Deficient Bracing of Exterior Elements p. 33
2. Poor Anchorage of Interior Elements p. 42

B.1 Deficient Bracing of Exterior Elements

Problem: Many exterior non-structural elements do not have bracing or connections sufficient to carry earthquake forces. These elements may fail during an earthquake, creating falling hazards and causing additional damage.

Mitigation Objective: Reduce or eliminate damage to non-structural elements by bracing, strengthening, reinforcing, or replacing elements and/or connections to withstand earthquake forces.

Mitigation measures to reduce earthquake damage to vulnerable exterior elements include:

- a. Brace Parapets p. 34
- b. Anchor Cornices and Architectural Elements p. 35
- c. Brace or Support Chimneys p. 36
- d. Remove, Relocate, or Replace Heavy Elements p. 37
- e. Replace Stone Facing with Lighter Material p. 38
- f. Secure Wall Panel Anchors p. 39
- g. Brace Large Windows p. 40
- h. Strengthen Window Glass p. 41

B.1.a Brace Parapets

Parapet damage or failure is a common result of earthquakes. Parapets can be braced from the rear using steel angle braces anchored into the parapet and connected to the roof framing. Parapets can also be braced using reinforced concrete or **shotcrete** placed behind the parapet and anchored. Reducing the height of parapets also reduces the seismic load on the parapet by reducing the weight.

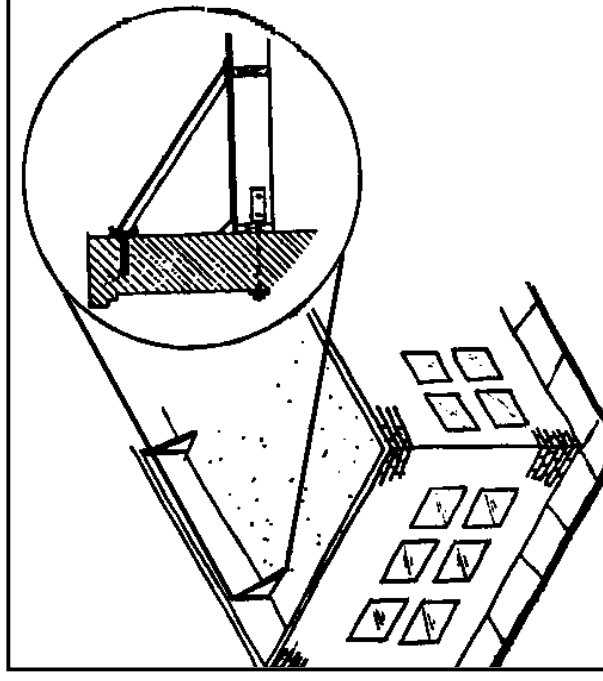

Effectiveness:

- Very effective.
- Consider adding **tension ties** and/or **shear anchors** to exterior walls to increase effectiveness.

Limitations:

- Parapet bracing will impose additional forces on roof elements of a building.

Considerations:



B.1.b Anchor Cornices and Architectural Elements

Architectural building elements such as cornices, corbels, and spandrels often fail during a seismic event. These building elements can be anchored from the outside by installing anchors with exterior washer plates, or from the inside using either countersunk plates and/or epoxy anchors. For heavy and ornate cornice work, the cornice can be removed and reconstructed by using a lighter material such as lightweight concrete or plaster.

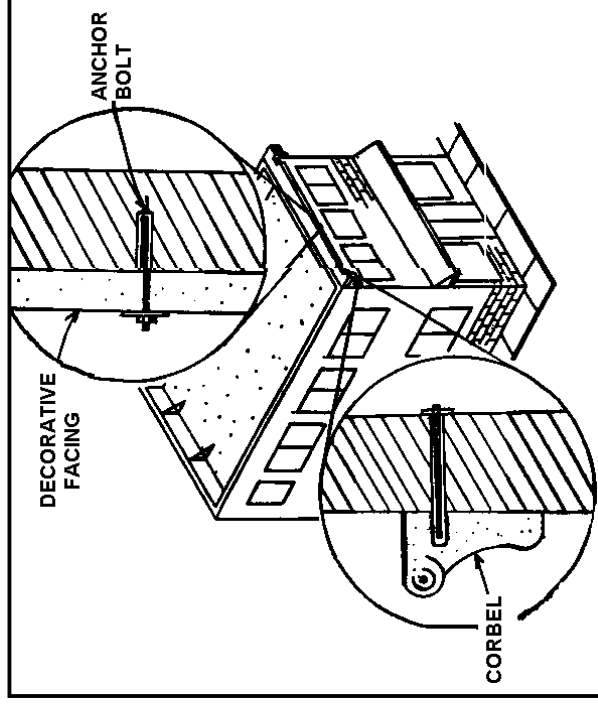

Effectiveness:

- Very effective.

Limitations:

- Elements should be checked to ensure they can carry the seismic loads imposed by the corrective measures (See p. 37).

Considerations:



B.1.c Brace or Support Chimneys

Chimneys on older buildings frequently suffer damage or collapse during earthquakes. Several retrofit methods can be used to mitigate damage:

- Chimney extensions above the roofline can be secured with steel straps anchored to the roof framing with steel angle braces.
- The chimney flue enclosure can be reinforced using vertical and horizontal bars encased in concrete.
- For multi-storied buildings, chimneys can be anchored at each floor level using steel wrap ties that are anchored to the floor joists.

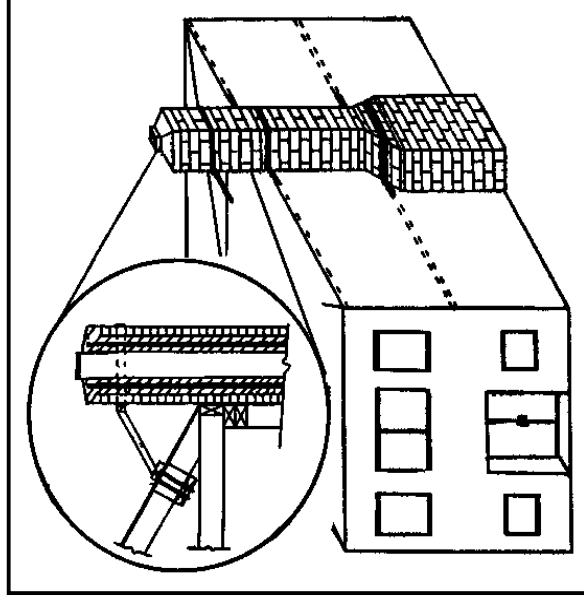

Effectiveness:

- Very effective.

Limitations:

- For large, complex chimneys, all elements should be checked to ensure mitigation will not exacerbate damage.
- May not be cost-effective for small, simple chimneys.

Considerations:



B.1.d Remove, Relocate, or Replace Heavy Elements

Stone awnings and decorative features may not have proper anchorage or reinforcement. The dead weight added by these elements can increase lateral forces. To reduce damage, heavy non-structural elements should be minimized. Such elements may be removed, relocated, or replaced using lighter materials, or replaced with an independent structure.

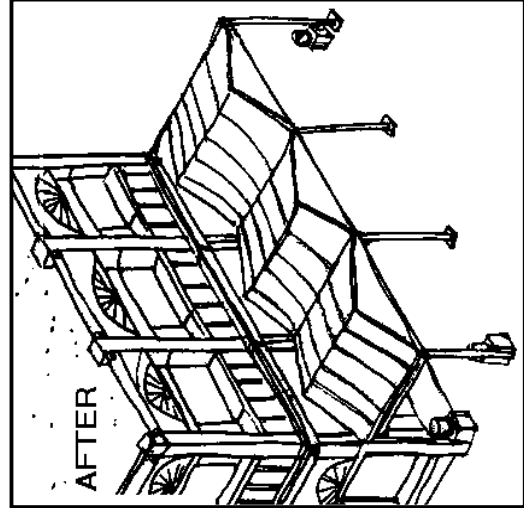
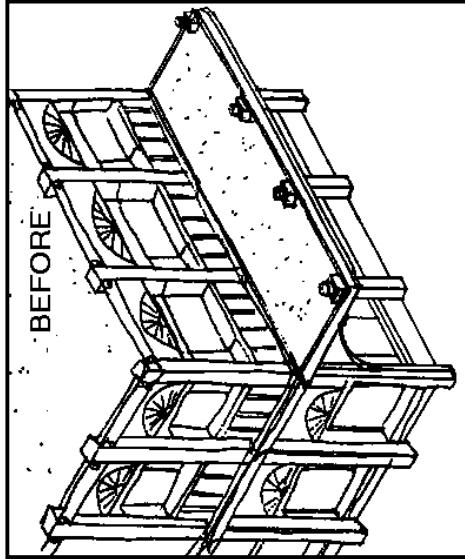

- Effectiveness:**
- Very effective.
- Limitations:**
- Lighter replacement elements or independent structures are still subject to damage.
- Considerations:**
- ▲
 - 👤

B.1.e Replace Stone Facing With Lighter Material

Earthquakes can cause the heavy stone facings of buildings to shake loose and fall. The dead weight added to the structure by the stone facing can increase seismic forces. Heavy stone facing can be replaced with lighter materials such as lightweight concrete, **shotcrete**, cement plaster (stucco) or a stone veneer. Many of these materials can be applied directly to the building and reinforced using steel or wire mesh.

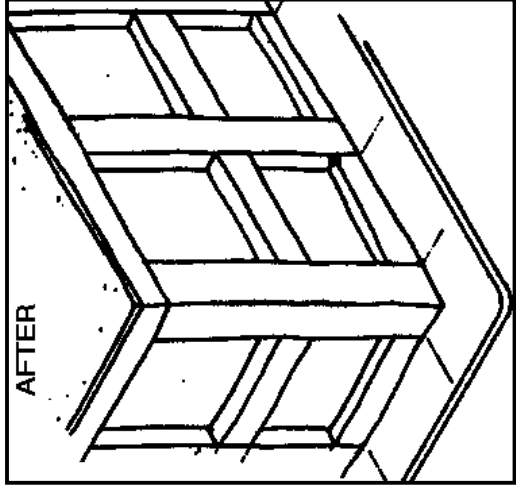
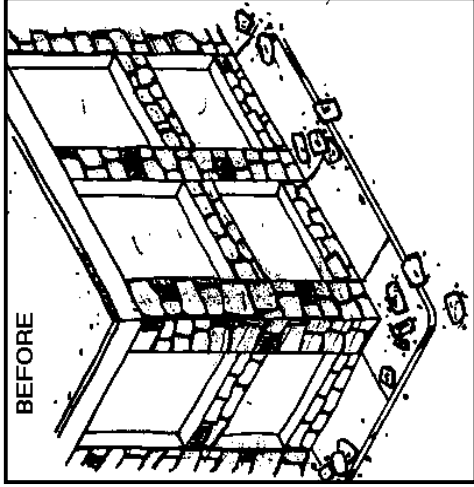

- Effectiveness:**
- Very effective.
- Limitations:**
- Lighter replacement materials are still subject to damage.
- Considerations:**
- ▲
 - \$
 - 🏗️

B.1.f Secure Wall Panel Anchors

During an earthquake, rigid wall panels attached to the exterior of steel-framed structures can be damaged due to insufficient flexibility in the connections to the frame. Connections can be modified to allow such flexibility to accommodate earthquake forces. The wall panel should be rigidly attached at the base and then held with a flexible rod at the top.

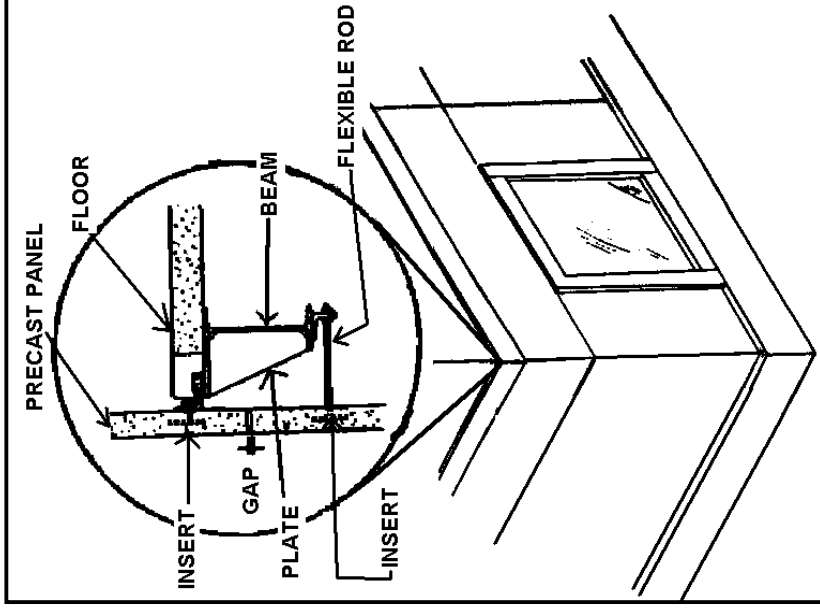

Effectiveness:

- Somewhat to very effective depending on the existing building condition.

Considerations:



B.1.g Brace Large Windows

The principle causes of glass breakage are window frame distortion and inadequate edge clearance around the glass. Stiffening bracing or redesigning of the window frame can reduce future damage. Bracing usually consists of steel tie rods anchored to the corners of the window frame and connected by a turnbuckle. Another method is to use specially designed windows that use wider frames and include a compressible material between the frame and the window glass to avoid direct contact between the window and the frame.

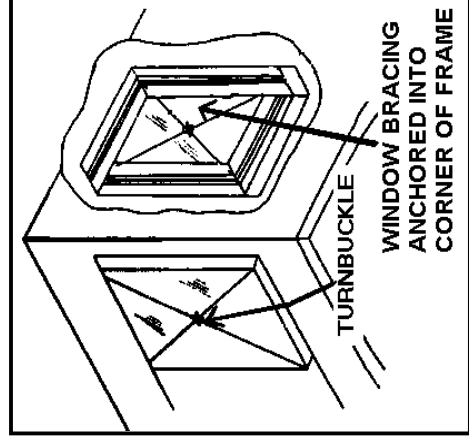
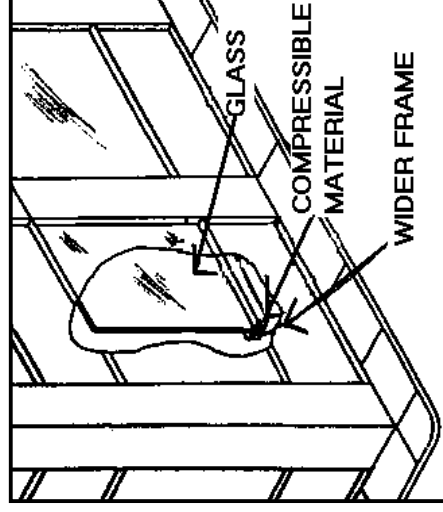

Effectiveness:

- Somewhat to very effective.

Limitations:

- Effectiveness limited by amount of bracing and size of the glass panels.

Considerations:

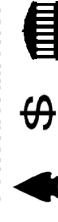

B.1.h Strengthen Window Glass

During an earthquake, window frames can experience extreme shaking or distortions that trigger glass breakage. Tempered glass is stronger than conventional glass and breaks into smaller, less dangerous fragments. Wire-reinforced glass, or adhesive film applied to existing windows, can hold the glass fragments together, reducing damage and falling hazards.

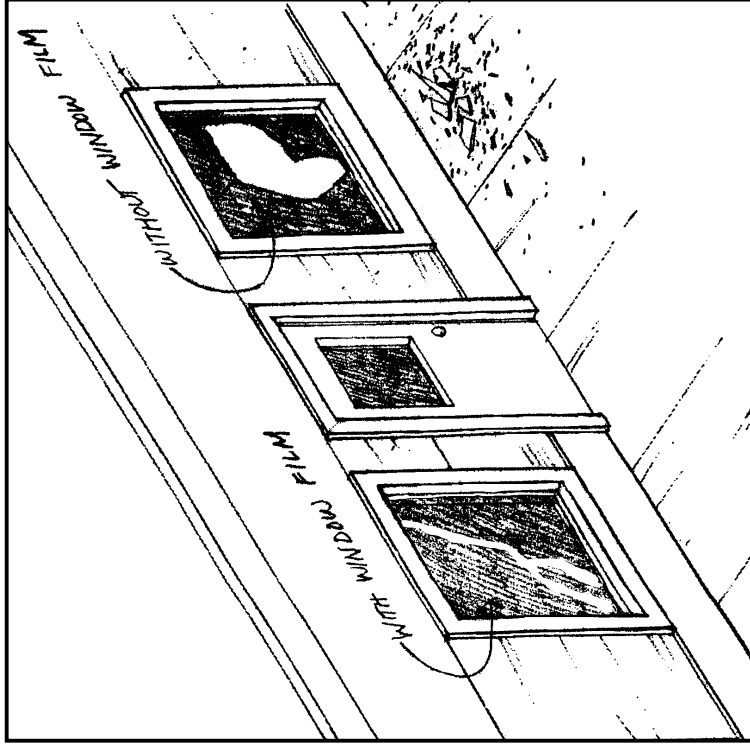

Effectiveness:

- Somewhat to very effective, and particularly effective for smaller windows.

Limitations:

- Effectiveness limited by structural framing and the size of glass panels.

B.2 Poor Anchorage of Interior Elements

Problem: Many interior non-structural elements do not have anchorage or connections that are sufficient to carry earthquake forces and movements. As a result, these elements may suffer failure during an earthquake, creating falling hazards and causing additional damage.

Mitigation Objective: Anchor interior non-structural elements by strengthening or reinforcing elements and/or connections to withstand earthquake forces and movements.

Mitigation measures to protect non-structural components of buildings from damage caused by poor anchorage of interior elements include:

- Secure Suspended Ceilings..... p. 43
- Secure Overhead or Pendant Lighting Fixtures..... p. 44
- Brace Interior Partitions..... p. 45
- Anchor Raised Computer Floors..... p. 46

B.2.a Secure Suspended Ceilings

Unbraced suspended ceilings can swing independently of the supporting floor and be damaged or fall. Installing 'four-way' diagonal wire bracing and compression struts between the ceiling grid and the supporting floor will significantly improve the ceiling's seismic performance. In addition to the struts, the connections between the main runners and cross runners should be capable of transferring tension loads.

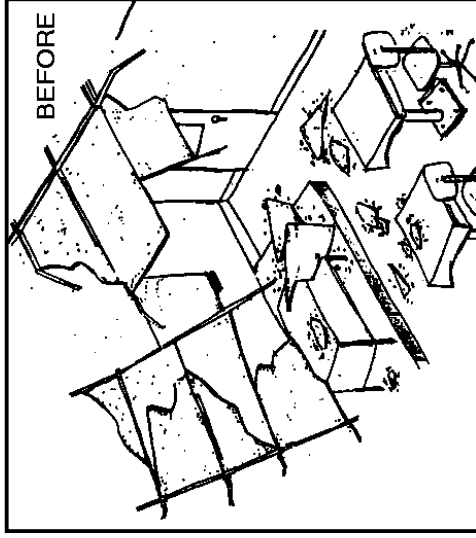

Effectiveness:

- Somewhat to very effective depending on strength of ceiling grid.

Limitations:

- Splices and connections of the runner sections that comprise the ceiling grid may need to be strengthened.

Considerations:

\$

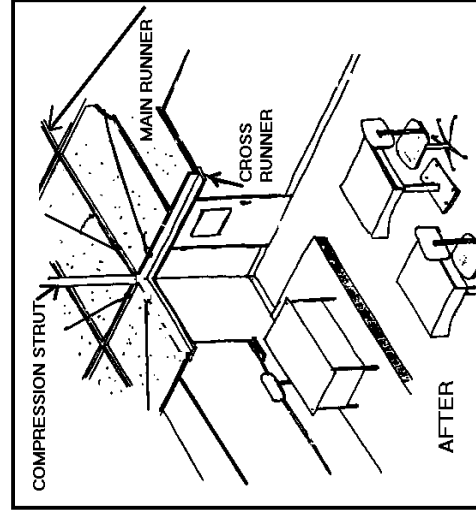

B.2.b Secure Overhead or Pendant Lighting Fixtures

During seismic shaking, overhead lighting fixtures can fail when the suspended ceiling sways and distorts. Electrical wires are often the only support for these fixtures. Independent wire ties connected from each fixture corner to the supporting floor can be added. Also, safety wires can reduce damage. Threaded metal conduit can protect the wiring and support the fixture, and wire straps or cages may prevent fluorescent tubes from falling.

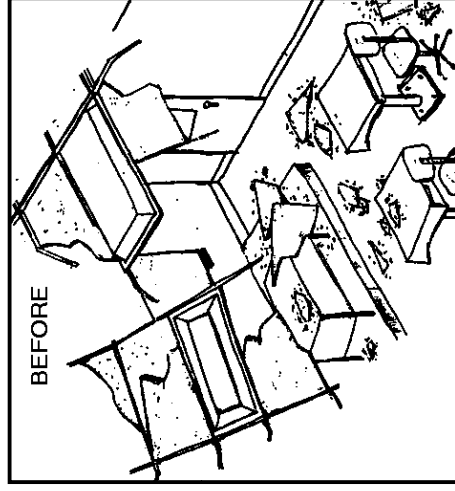

Effectiveness:

- Very effective.

Considerations:

\$

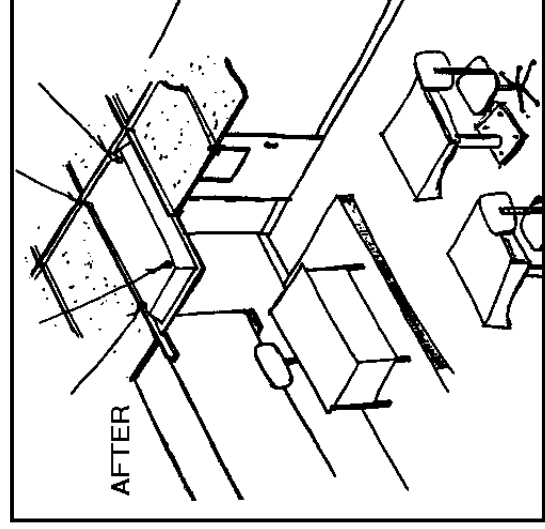

B.2.c Brace Interior Partitions

Interior partitions can fail during an earthquake. Retrofitting can be done with connections that restrict the partitions from sideways movement while allowing vertical movement. Interior partitions generally need lateral support from ceilings or from the floor or roof framing. Unreinforced masonry partitions can also be replaced with drywall partitions.

Unbraced partitions that do not extend to the floor or roof framing should be braced to the framing. Steel channels are sometimes provided at the top of the partition to provide lateral support, and allow some floor or ceiling movement without imposing any loads on the partition.

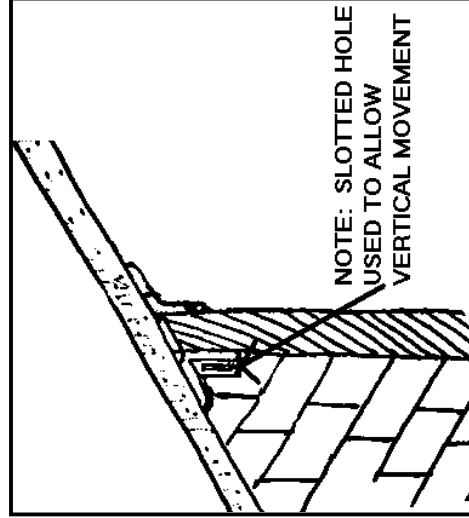
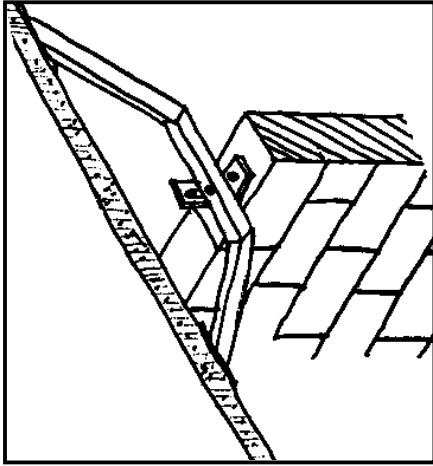

NOTE: SLOTTED HOLE USED TO ALLOW VERTICAL MOVEMENT

Effectiveness:

- Somewhat effective.

Limitations:

- Effectiveness limited by the strength of the partition.

Considerations:



B.2.d Anchor Raised Computer Floors

Raised computer floors may collapse from earthquake forces. To reduce the risk for this type of damage, anchor the pedestals that support the raised flooring to the building's floor and secure the pedestals to the wall.

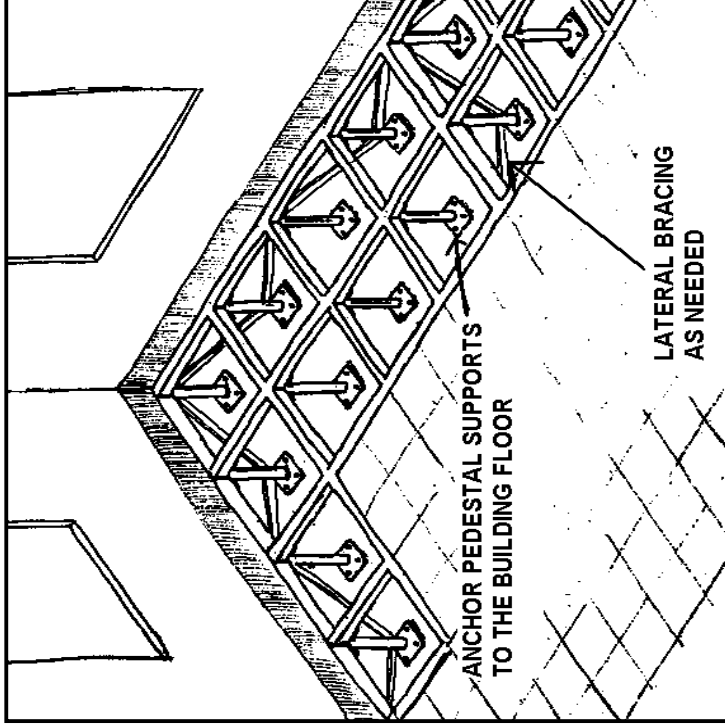

Effectiveness:

- Somewhat to very effective.

C. Building Utility Systems

Introduction

Building utilities include heating, ventilation and cooling (HVAC), electricity, gas, water, wastewater, communications, and elevator systems. The basic components of building utility systems include supply and storage equipment, pipelines, and ductwork as well as the connections between these components.

Building utility systems commonly suffer earthquake damage for two reasons:

1. Heavy utility equipment and supply lines are often poorly secured to the structural elements of the building, and are not usually designed for lateral earthquake forces.
2. Supply line connections are often too weak or inflexible to withstand lateral earthquake forces.

Types of Damage. Below are some typical types of building utility system damage caused by earthquakes:

Heavy Equipment. Heavy equipment are commonly mounted on roofs or in basements and are damaged where they are not supported or anchored properly.

Elevator Systems. Most elevator systems consist of a passenger cab and a counterweight connected to each other by cables. The cab and counterweight run along two sets of vertical rails that are housed within the elevator shaft. Earthquake damage to elevators typically occurs where the elevator counterweight rails are not adequately braced, allowing the elevator counterweight to swing loose from its rails and collide with the walls of the shaft or even the cab.

Supply Lines. Supply lines for building utilities include pipes and joints for gas, water, and wastewater, electrical conduits, and HVAC ductwork. These lines run along or within walls, floors, and ceilings. Damage to supply lines typically occurs along unsupported line sections. Secondary damage may include water damage from leaking water or wastewater

lines, or fire or explosion damage caused by leaking gas or electrical lines.

Connections. Connections between supply lines are encountered throughout a building. Damage usually occurs where connections are not strong or flexible enough to withstand movements between the lines and the equipment. Secondary damage may include water, fire, or explosion damage caused by leaking lines.

A structural engineer may need to be consulted to identify appropriate mitigation. All mitigation is not appropriate for all buildings or building utility systems. **Be aware** that choosing the wrong measure may cause more problems than not doing any retrofit at all.

Mitigation measures to protect building utility systems from earthquake damage include:

1. Poor Anchorage of Equipment p. 49
2. Improper Connections p. 54

C.1 Poor Anchorage of Equipment

Problem: Heavy building utility equipment such as HVAC compressors often do not have adequate anchorage to carry earthquake forces. As a result, such equipment can topple over or break loose during an earthquake.

Mitigation Objective: Anchor or protect heavy building utility equipment to withstand earthquake forces and movements.

Mitigation measures to protect building utility systems from damage caused by poor anchorage include:

- a. Anchor Heavy Equipment..... p. 50
- b. Secure Propane Tanks or Gas Cylinders..... p. 51
- c. Secure Elevator Counterweights..... p. 52
- d. Install Elevator Seismic Cutoff System..... p. 53

C.1.a Anchor Heavy Equipment

Seismic forces, combined with heavy equipment weight, can stretch vibration isolator springs beyond their ability to rebound, causing the isolators to fail, equipment to be overturned, and/or utility line connections to break.

Anchoring equipment directly to the floor or another suitable part of the building is preferable to mounting equipment on vibration isolators. If isolators are used, they should be securely anchored and equipped with snubbers. Snubbers allow small movement, but will prevent the equipment from moving beyond the limits of the springs.

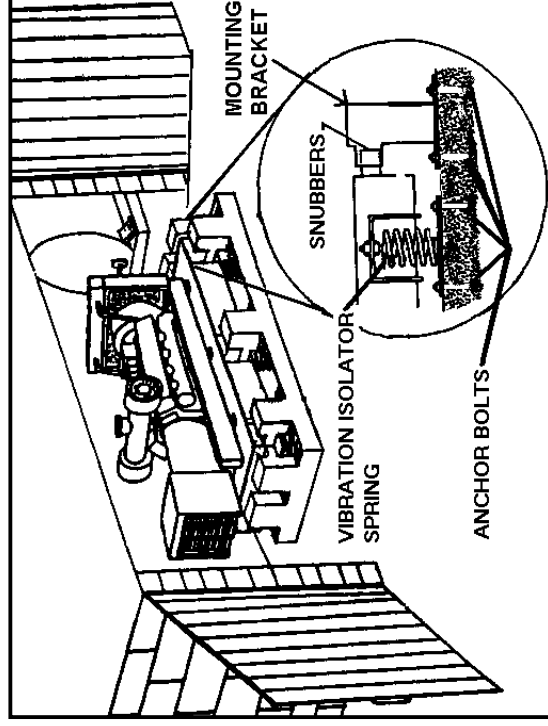

Effectiveness:

- Very effective when properly installed.
- Consider use of a flexible connection on the supply line to maximize effectiveness (See p. 57).

Limitations:

- Equipment on isolators must be able to move freely.
- Before anchoring equipment, verify that floors/walls are capable of resisting earthquake forces.

C.1.1.b Secure Propane Tanks or Gas Cylinders

During earthquakes, propane tanks or gas cylinders can break, fall, or rupture the supply line, creating fire and explosion hazards. Tanks and cylinders should be anchored and braced with metal straps. To secure a compressed gas cylinder to a wall, use two lengths of chain around the cylinder.

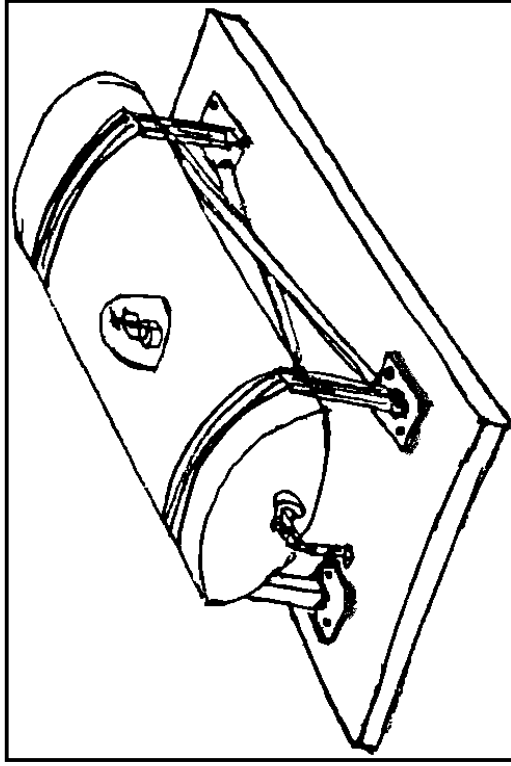

Effectiveness:

- Very effective.
- Consider use of a flexible connection on the supply line to increase effectiveness (See p. 57).
- On larger tanks, consider installing a seismic shutoff valve that will automatically turn off the gas (See p. 58).

C.1.1.c Secure Elevator Counterweights

During an earthquake, elevator damage often occurs when the elevator counterweight derails and collides with the cab or the elevator shaft. Counterweights should be properly secured by bracing the counterweight rails. Both bracing and rails should be securely attached to the building. Retainer plates can be added to the top and bottom of the counterweights and to the cars to prevent the counterweights from becoming dislodged from the rails.

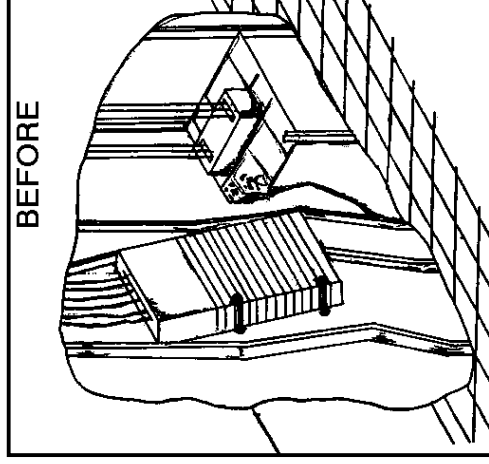

Other measures to reduce elevator damage: 1) Anchor elevator machinery and controller units to prevent the units from sliding or toppling; 2) Install retainer plates to prevent the wire ropes from moving off the chain; or 3) Install guards on the rail brackets so that ropes, chains, and/or cables will not snag.

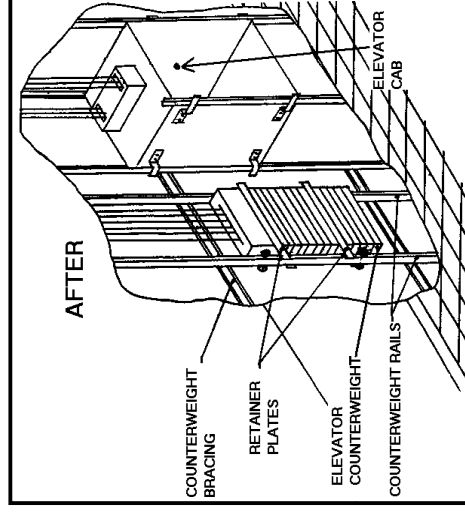

Effectiveness:

- Very effective.

Considerations:



C.1.d Install Elevator Seismic Cutoff System

During an earthquake, if an elevator's counterweight derails and swings free near the same floor as the cab, the two can collide and cause major damage. Installing a seismic cutoff system will reduce this type of damage.

Cutoff systems are designed to move the elevator cab to a floor away from the counterweight, open the cab doors to let passengers out, and shut down the elevator.

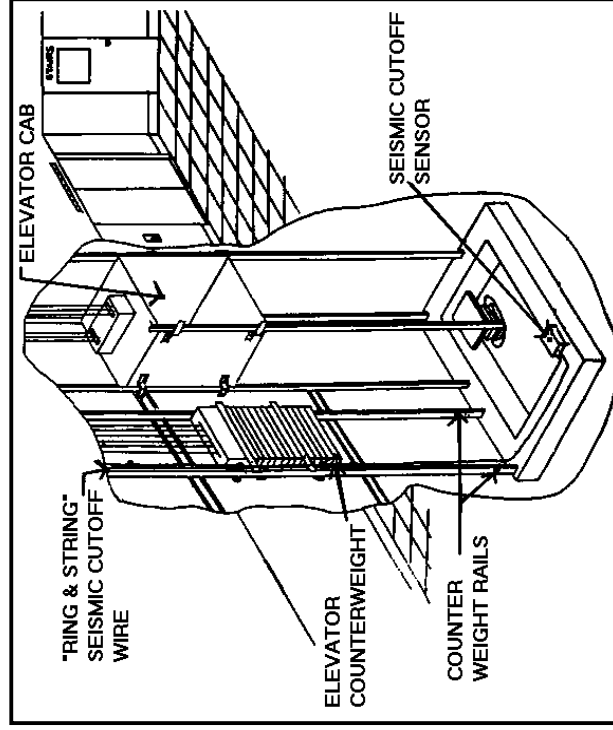

Effectiveness:

- Somewhat to very effective in reducing damage to the cab, depending on the extent that moving parts are braced.
- For maximum effectiveness, brace counterweight rails.

Considerations:



C.2 Improper Connections

Problem: Connections between supply line sections and equipment are commonly not strong or flexible enough to carry earthquake forces. Also, some utility supply lines are not properly braced to withstand lateral earthquake forces, causing the lines to crack, leak, or collapse. Both of these situations can trigger additional building damage ranging from water leaking to electrical fires and gas explosions.

Mitigation Objective: Secure or protect building utility connections and supply lines to withstand earthquake forces.

Mitigation measures to protect building utility systems from damage caused by improper connections include:

- Brace Overhead Utility Pipes..... p. 55
- Secure HVAC Ducts p. 56
- Install Flexible Connections..... p. 57
- Install Shut-Off Valves..... p. 58

C.2.a Brace Overhead Utility Pipes

Overhead utility pipes frequently become loose and fall, damaging the utility system during an earthquake. Bracing and restraining utility pipes can greatly reduce earthquake damage. There are several methods for bracing pipes, including hangers, straps, stirrups, and angle braces. Larger horizontal pipe and fittings should be braced at every joint, branch, and change of direction.

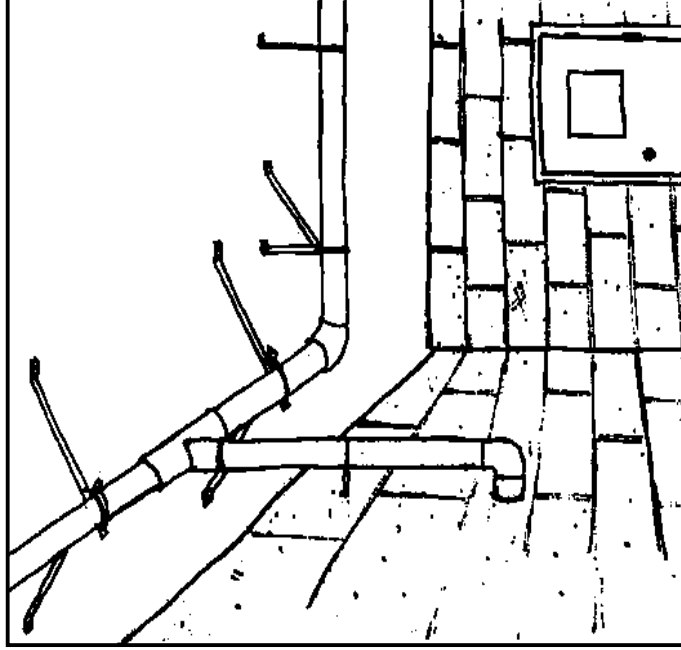

Effectiveness:

- Somewhat to very effective, depending on the number and spacing of bracing.
- Consider flexible connections to maximize effectiveness.

Limitations:

- If piping is suspended over 18 inches, install sway bracing with non-rigid hangers.

Considerations:



C.2.b Secure HVAC Ducts

In an earthquake, HVAC and other ductwork can warp and collapse. Bracing should be installed so that during an earthquake the ducting will remain securely suspended with the joints intact, and will be restrained from rocking.

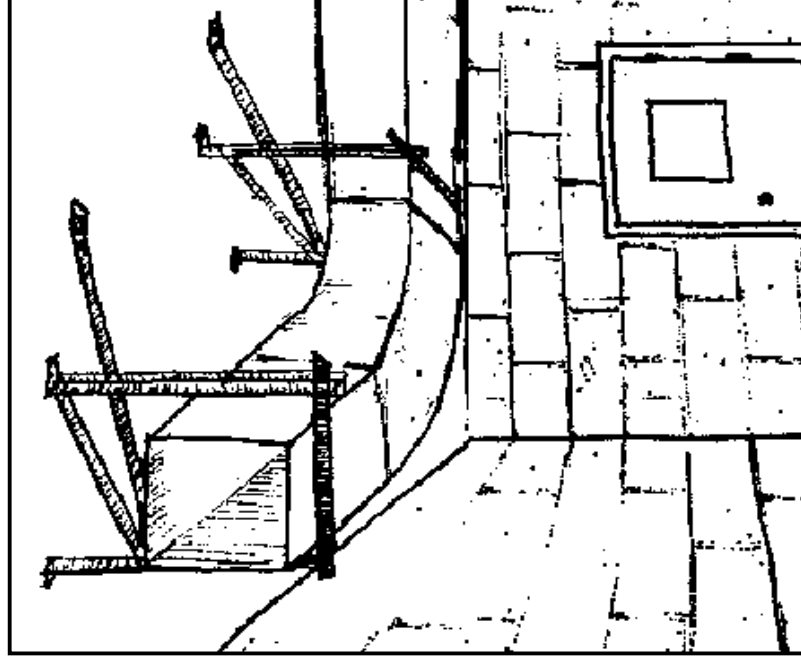

Effectiveness:

- Somewhat to very effective, depending on the number and spacing of bracing.

Considerations:



C.2.c Install Flexible Connections

Because most utility lines are rigid, they can be torn from their connection points during an earthquake. Flexible connection pipes or conduits between equipment and their supply lines will reduce future damage. Flexible lines should follow a U-shaped path to allow relative movement in all directions.

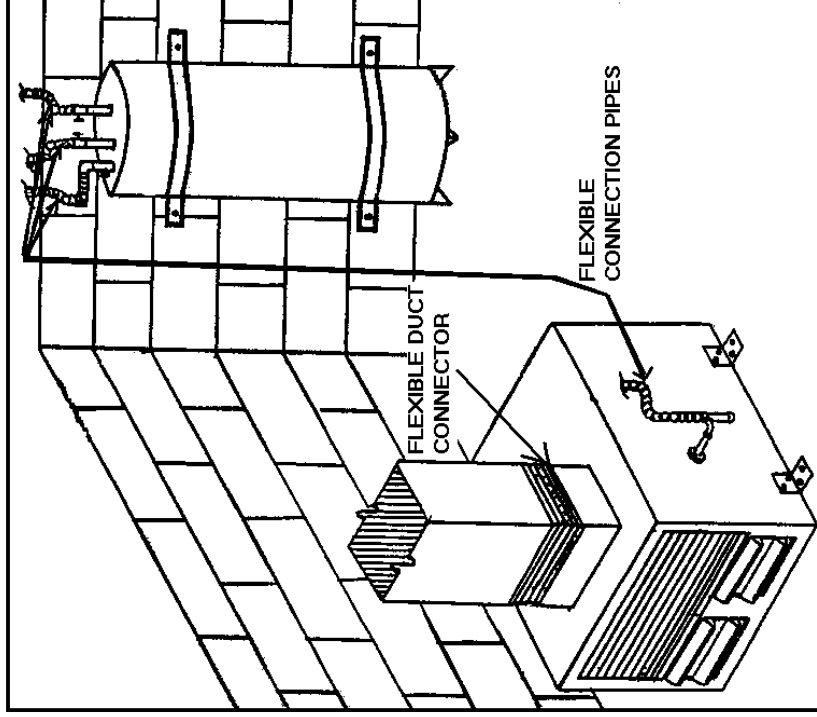

Effectiveness:

- Very effective.
- Consider anchoring the equipment to the floor or wall to increase effectiveness.

C.2.d Install Shut-Off Valves

During an earthquake, fires and explosions can occur as a result of ruptured gas lines. A seismic gas shut-off valve cuts the flow of gas in the event of an earthquake. The valve has a mechanism to block the flow of gas when ground movement occurs.

An alternate to seismic shut-off valves is a gas protection system which stops the flow of gas when a sensor detects a gas leak or a higher than expected flow rate.

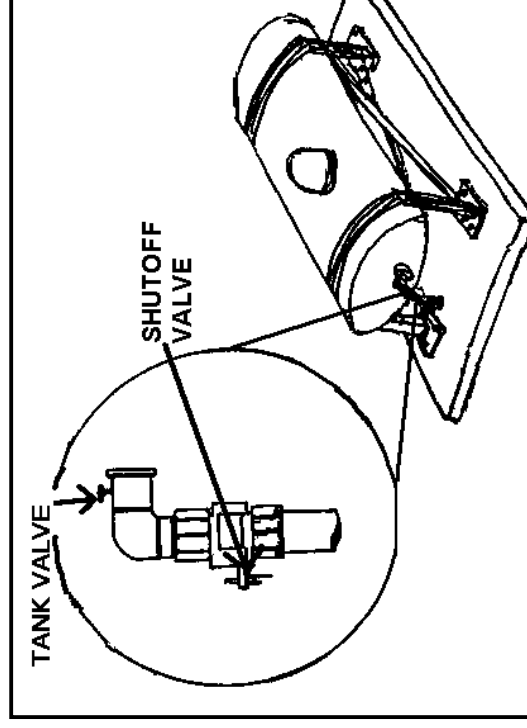

Effectiveness:

- Very effective.

Limitations:

- Qualified professionals should install shut-off valves.
- Valves generally activate around 5.2 to 5.4 on the Richter scale, whether or not there is damage.
- A qualified professional may be required to reset shut-off valves.

D. Building Contents

Introduction

Building contents include all furnishings and equipment such as tables, chairs, bookcases, file cabinets, cubicle wall partitions, computers, or wall hangings. While building contents are generally not connected to structural building elements, they do rely on them for support. As a result, building contents can shake and move around during earthquakes.

Types of Damage. Typical earthquake-related damage to building contents are described below:

Heavy Furnishings. Large bookcases and file cabinets are found in most buildings. These heavy furnishings are often top-heavy or overloaded, and can fall over unless they are anchored to the floors and/or walls of the building.

Computers and Equipment. Computers, monitors, and other equipment are common in buildings, and may be critical to operations. These items are heavy, fragile, and can fall unless they are secured to the furnishings that support them.

Hazardous Materials. Compressed air tanks, corrosive chemicals, and other hazardous materials are found in various buildings. These items are heavy, dangerous, and can fall, leak, or rupture unless they are anchored to walls or secured to furnishings that support them. Secondary damage can include damage from leaking chemicals, or fire or explosion damage.

Since contents are supported by structural elements, a structural engineer may need to be consulted to identify if certain mitigation measures are appropriate for a given building. Some measures involving heavy furnishings and equipment included here are not appropriate for all buildings.

This section will discuss mitigation measures to protect building contents from damage due to:

1. Movement of Furnishings..... p. 60

D.1 Movement of Furnishings

Problem: Furnishings and other building contents are often not secured to protect from movement caused by earthquake-induced ground shaking. As a result, such items can tip over or fall during an earthquake, damaging the equipment and creating additional hazards.

Mitigation Objective: Secure furnishings and other building contents to resist movement from earthquake-induced ground shaking.

Mitigation measures to protect the contents of buildings from damage caused by movement of furnishings include:

- a. Restrain Desktop Computers & Equipment..... p. 61
- b. Secure Hazardous Materials p. 62
- c. Anchor Automated Filing System p. 63
- d. Secure Miscellaneous Furnishings p. 64

D.1.a Restrain Desktop Computers & Equipment

Tremors can easily move personal computers and other small equipment causing them to fall. Restraining these items can protect small equipment from earthquake damage. Some methods, such as Velcro fasteners, require no tools. Others, which include using chain, cables, or elastic cords, require simple hand tools. Anchor the ends of chains, cables, clips, or elastic cords to either the wall or the surface of the desk, table, or counter using eyehooks, rings, screws and washers, or other types of mounts.

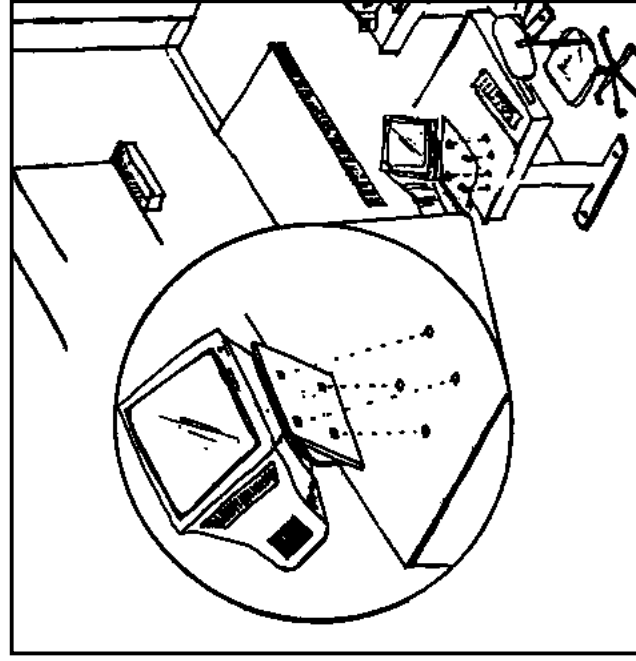

- Effectiveness:**
- Very effective.
 - Furniture supporting equipment should be anchored to the floor or wall for maximum effectiveness.

D.1.b Secure Hazardous Materials

The movement and spillage of hazardous materials can cause damage as well as risk for human injury. Seismic-activated shutoff valves should be installed on hazardous materials supply lines, with flexible connections provided at the storage tanks. Bottles of laboratory chemicals should be prevented from falling by using elastic straps, shelf lips, or cabinet door locks.

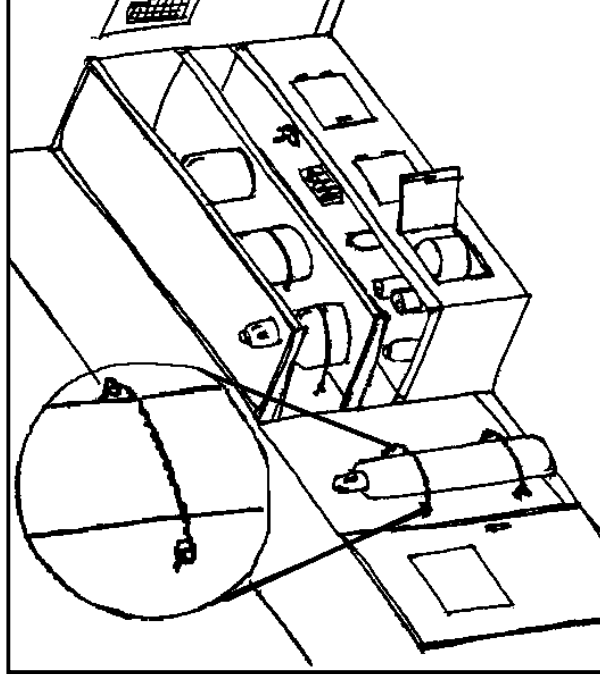

- Effectiveness:**
- Very effective.

D.1.c Anchor Automated Filing Systems

Many public buildings house records in heavy, filing system carousels. During an earthquake, these automated filing systems can fall, causing damage and even injuries. To reduce damage and risk for injury, the automated filing system can be secured to the floor using seismic anchors bolts on all four corners, so that they remain upright during a seismic event. The seismic anchors should be long enough to secure the carousels into the floor slab.

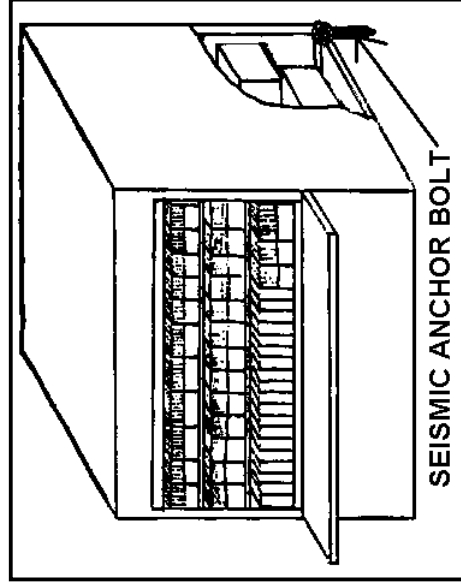

Effectiveness:

- Very effective when properly installed.

Limitations:

- Installation of seismic anchors requires partial disassembly, reframing, rebalancing, and reassembly of filing system carousels.

- Qualified professionals should install seismic anchors for filing system carousels.

Considerations:

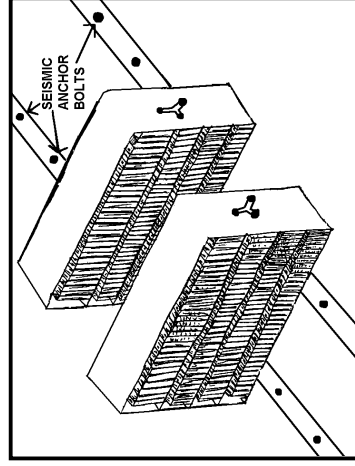

D.1.d Secure Miscellaneous Furnishings

Miscellaneous furnishings such as freestanding partitions, display cases, bookcases/file cabinets, heavy objects on high shelves, and framed pictures can be secured in various ways.

- 1) Anchor freestanding partitions to the floor, or attach them to large desks or other stable furnishings, or arrange in a zig-zag pattern.
- 2) Secure display cases to the walls with angle brackets and bolt to the floor (metal wire or elastic guardrails added to top shelves to protect contents).
- 3) Anchor furniture, making sure screws are long enough to go through the wall and the stud.
- 4) Redistribute heavy

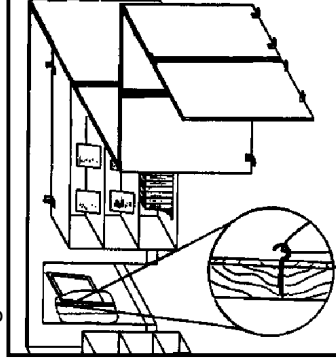

items on to lower shelves to stabilize weight. 5) Secure framed pictures and mirrors either by using long-shank or open eyehooks securely screwed to the frame (instead of wire across the back of the frame).

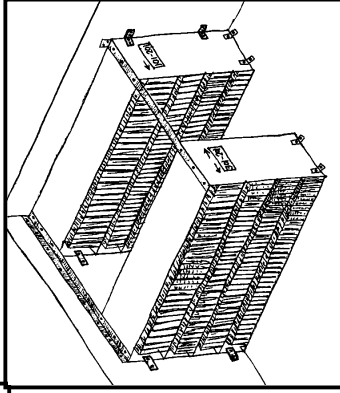

Effectiveness:

- Somewhat to very effective.

- Anchoring heavy file cabinets and other equipment can increase effectiveness.

Limitations:

- Light furnishings may be more prone to damage.

Considerations:

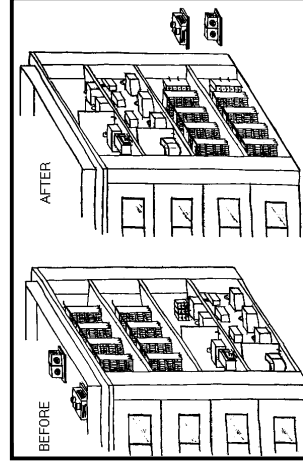

BRIDGES

Introduction

There are two primary reasons for bridges' vulnerability to earthquake damage. First, about 60 percent of the nation's current 575,000 bridges were built before 1970 when there were no design requirements for earthquake resistance. A second reason is due to bridges being very simple structures. Unlike a building structural system, a bridge does not have many alternate load paths. When one structural element of a bridge fails, there is the chance the entire bridge might collapse.

BRIDGES

Types of Earthquake Damages to Bridges

Pier failure. Piers can buckle and even snap in an earthquake, making them appear to have been torn sideways, or even causing the bridge to tip over.



ELEMENTS OF A BRIDGE:

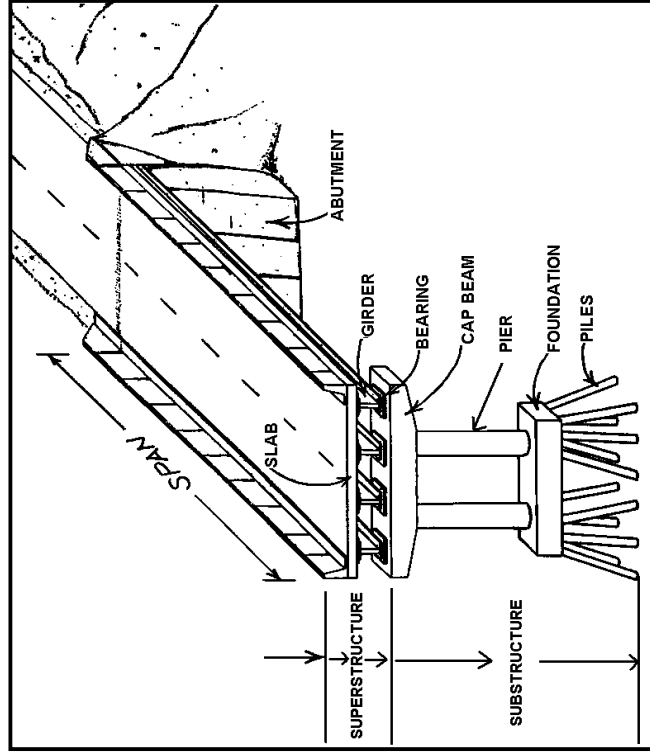

Slab failure. Piers may separate from the bridge slab and break through the slab, causing "punching shear."

Span failure. Damage may vary from one end of a span on the ground to an inch or two variance between the deck height of adjoining spans.

Cap beam failure. Often the only sign of this failure is extensive cracks in the cap beam.

Earthquake-related damages to bridges may be caused by:

- A. Pier Failure p. 67
- B. Slab Failure p. 70
- C. Span Failure p. 74
- D. Cap Beam Failure p. 82

A. Pier Failure

Problem: Forces generated during an earthquake can cause bridge piers to buckle and even snap. Such pier failure can have a damaging domino effect on the other bridge elements.

Mitigation Objective: Enable piers to better endure earthquake loads by enhancing the strength of existing piers and/or by adding additional piers.

Mitigation measures to protect bridges from pier failure include:

1. Confine Piers With Jackets..... p. 68
2. Strengthen Bridge by Installing Additional Piers..... p. 69

BRIDGES

A.1 Confine Piers With Jackets

Bridge piers can fail in an earthquake because the concrete can not restrict the movement of the reinforcing steel in the pier. Placing a **steel jacket** around the pier may prevent such failures. The steel jacket confines the reinforcing steel in the pier and significantly increases ultimate pier strength. Fiberglass or **carbon fiber wraps** may be used in place of steel jackets.

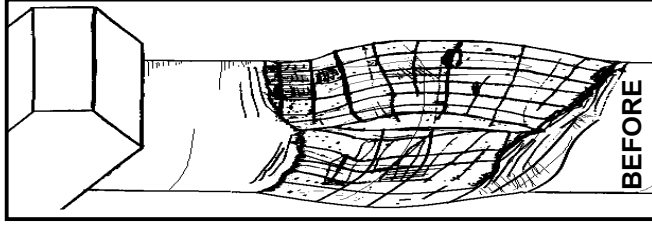

Effectiveness:

- Very effective.

Limitations:

- Less effective for rectangular piers.
- Qualified professionals should install pier jackets.

Considerations:



A.2 Strengthen Bridge by Installing Additional Piers

Bridge piers can fail during an earthquake and cause an entire bridge to collapse. Additional piers can be installed to prevent this failure. Additional piers will reduce forces carried by the existing piers and increase the overall strength of the bridge.

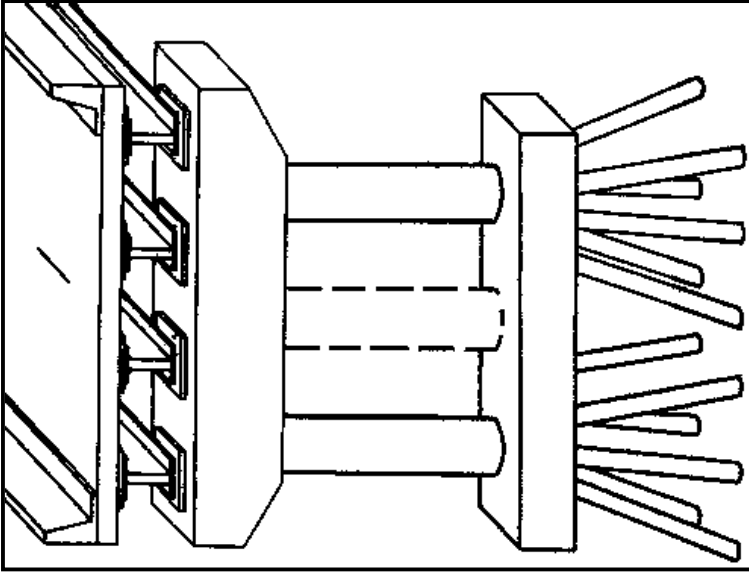

BRIDGES

B. Slab Failure

Problem: Earthquake forces can cause a bridge slab or deck to experience punching shear failure. This failure occurs when piers separate from the slab and are dramatically forced upward - or punch - through the slab or deck.

Mitigation Objective: To increase seismic resistance to punching shear by protecting or reinforcing the slab.

Mitigation measures to protect bridges from slab failure include:

1. Protect Slab by Adding Pier Caps..... p. 71
2. Protect Slab by Adding Piers..... p. 72
3. Strengthen Slab by Increasing Thickness p. 73

Effectiveness:

- Very effective.
- For maximum effectiveness, consider retrofitting all piers with **steel jackets**.

Limitations:

- May require new foundations for additional support.

Considerations:



BRIDGES

B.1 Protect Slab by Adding Pier Caps

Severe earthquake forces can cause punching shear failure of a bridge. This occurs when one or more piers break or punch through the bridge slab. An effective way to prevent this failure is to widen the tops of the piers using pier caps.

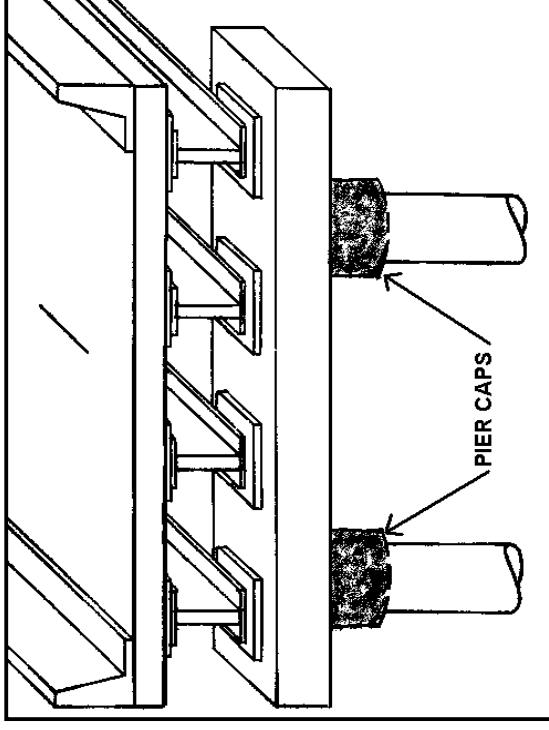

Effectiveness:

- Very effective.

Limitations:

- Must be solidly attached to columns or effectiveness is limited.

Considerations:



B.2 Protect Slab by Adding Piers

Another effective method to prevent punching shear failure is to increase the area of the steel beams horizontally and then add piers on both sides of the bridge. This will protect the slab against punching shear by spreading the pier forces over a wider area.

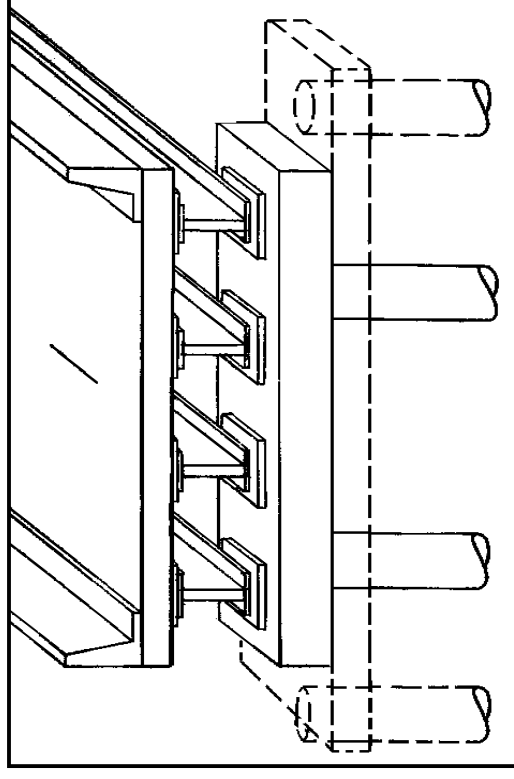

Effectiveness:

- Very effective.

Considerations:

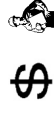

\$

B.3 Strengthen Slab by Increasing Thickness

Bridge slabs may sustain punching shear failure during an earthquake. Increasing the slab thickness can prevent this failure by strengthening the slab and increasing its resistance to punching shear.

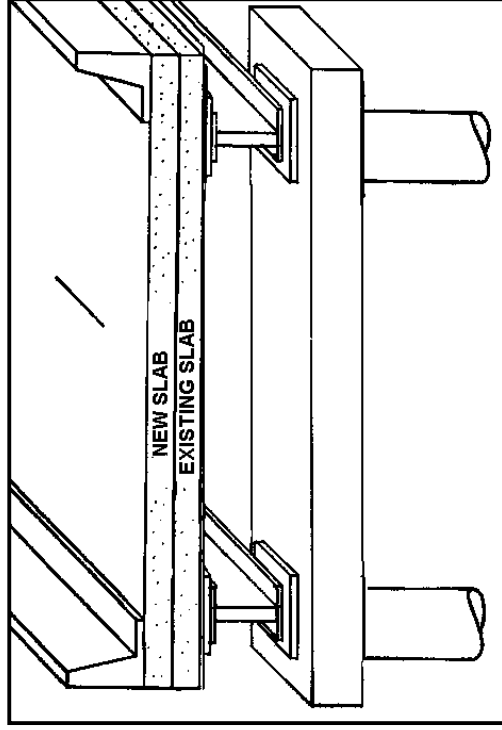

BRIDGES

C. Span Failure

Problem: During an earthquake, a bridge may rock back and forth, either lengthwise, side-to-side, or both directions. This rocking response can force the bridge spans to separate at the joints and unseat, or fall off the supporting platforms. Multi-span bridges with tall piers are especially susceptible to this type of span failure.

Mitigation Objective: Reduce the risk for movement of the bridge by strengthening bridge connections.

Mitigation measures to protect bridges from span failure include:

1. Add Cable Restainers..... p. 75
2. Construct Shear Blocks p. 76
3. Brace Spans by Installing Diaphragms p. 77
4. Extend Bearing Seats p. 78
5. Add Lock-Up Devices to Joints..... p. 79
6. Add Isolation Bearings p. 80
7. Eliminate Simply Supported Spans..... p. 81

Effectiveness:

- Very effective.

Considerations:



BRIDGES

C.1 Add Cable Restrainers

One of the simplest ways to reduce span failure is to use **cable** or bar **restrainers**. The restrainers are anchored across the joint holding the adjoining spans together. The restrainers transfer seismic forces to adjacent beams during earthquakes though allowing small movements of the superstructure under normal conditions.

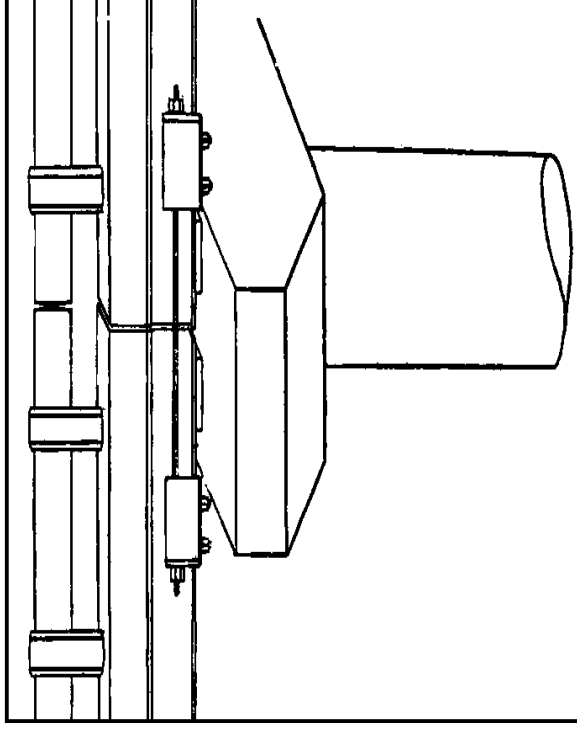

Effectiveness:

- Somewhat to very effective.
- Combine with **shear blocks** for maximum effectiveness.

Limitations:

- Does not protect against sideways or lateral movement of spans.

Considerations:



C.2 Construct Shear Blocks

During an earthquake, unseating of girders can lead to span collapse. Bridge spans separate from joints and fall off their supports. Reinforced concrete **shear blocks** anchored into the cap beams will help prevent lateral movement in the bridge.

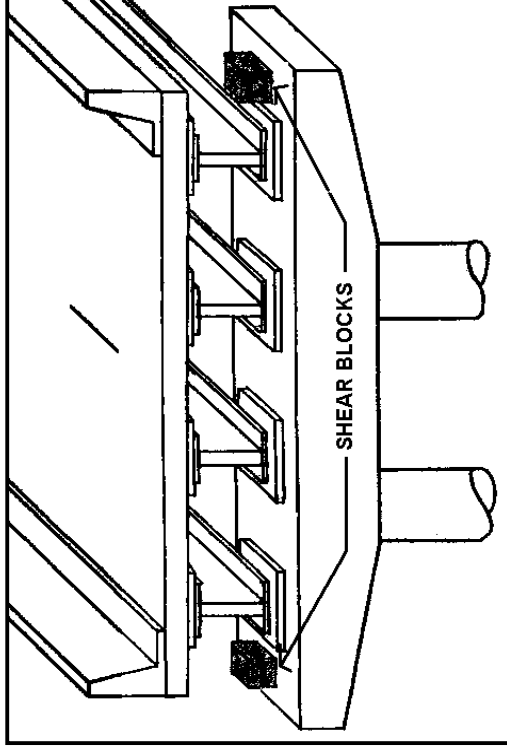

Effectiveness:

- Somewhat effective.
- Combine with addition of **cable restrainers** for maximum effectiveness.

Limitations:

- Shear blocks do not provide protection from damage by spans moving longitudinally.

Considerations:



C.3 Brace Spans by Installing Diaphragms

Adding diaphragms can help reduce the risk of span failure. Diaphragms are cross braces between girders and are used to minimize the flexing of the bridge spans caused by earthquake forces. The diaphragms distribute lateral forces between girders, enhance performance, and reduce overall seismic displacements.

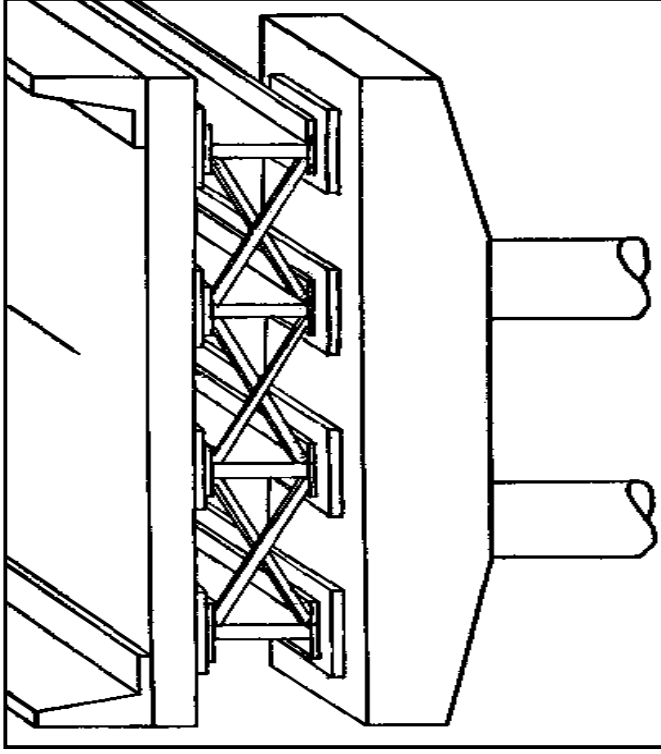

Effectiveness:

- Somewhat to very effective depending on condition of existing structure.

Considerations:



BRIDGES

C.4 Extend Bearing Seats

Bearing seats are the portion of the pier which supports the bridge girders. When an earthquake occurs, slippage and/or movement of the girder may occur if the bearing seats are not wide enough to support bridge girders. Seat extensions can be used to increase support of the girders and reduce risk of failure due to earthquake motion. Bearing seat extensions should be supported directly on the foundation to provide maximum protection.

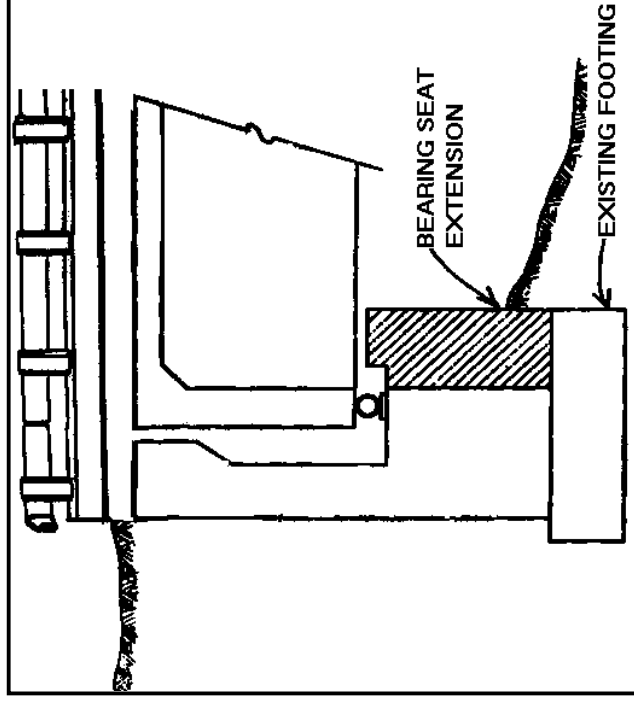

Effectiveness:

- Somewhat effective.

Limitations:

- Extensions anchored into the vertical face of a concrete pier rather than the foundations may not be as effective.

Considerations:



C.5 Add Lock-Up Devices to Joints

Joints between bridge decks and their supporting abutments or piers are vulnerable to earthquake forces. To strengthen these elements and reduce damage, lock-up devices are bolted to brackets mounted at the joints. Under normal conditions, lock-up devices move with the bridge deck under slow acting forces (thermal, shrinkage, or creep). Then in an earthquake, the devices 'lock up' and allow the entire span of the bridge to share the earthquake load, increasing structural integrity and reducing joint failure.

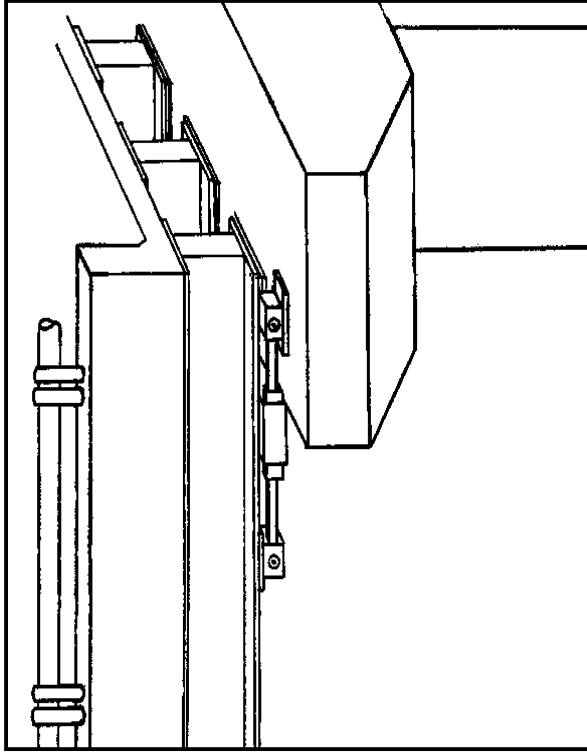

BRIDGES

C.6 Add Isolation Bearings

Seismic *isolation bearings* (acting like shock absorbers) can increase resistance to earthquake forces and reduce risk to span failure. Isolation bearings provide load support and flexibility. The bearings are flexible enough to absorb lateral movement from earthquake ground motion, so the earthquake forces transmitted through the structure are greatly reduced.

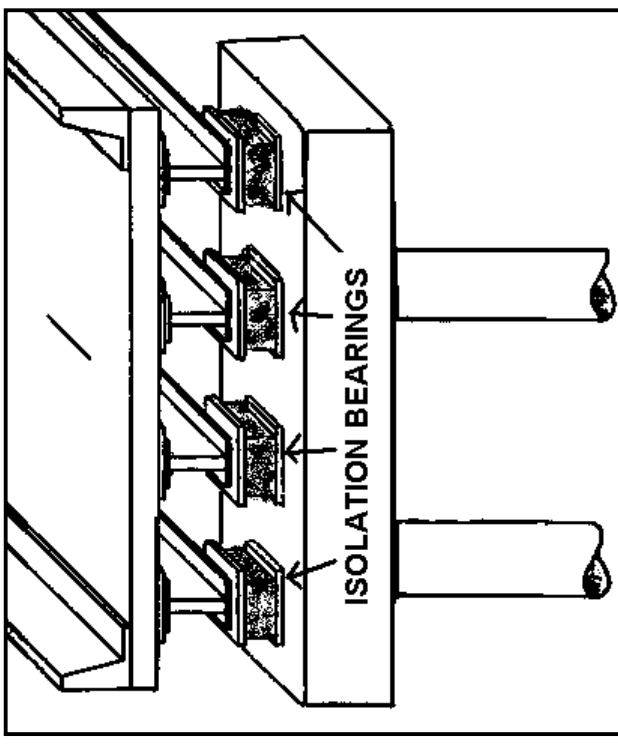

Effectiveness:

- Very effective.
- As lock-up devices allow for bridge deck contraction and expansion, it is not advised they be used in conjunction with other mitigation methods.

Considerations:



Effectiveness:

- Very effective.

Considerations:



C.7 Eliminate Simply Supported Spans

When bridge structures are constructed with several distinct spans (simply supported spans) they are highly vulnerable to earthquake damage. These spans react to forces independently of each other and are not very earthquake resistant. Combining these spans into one continuous span can increase resistance. Adding continuity to simple spans generally involves eliminating **expansion joints** in the bridge deck, adding splices between girders of adjacent spans, and reducing the number of bearings.

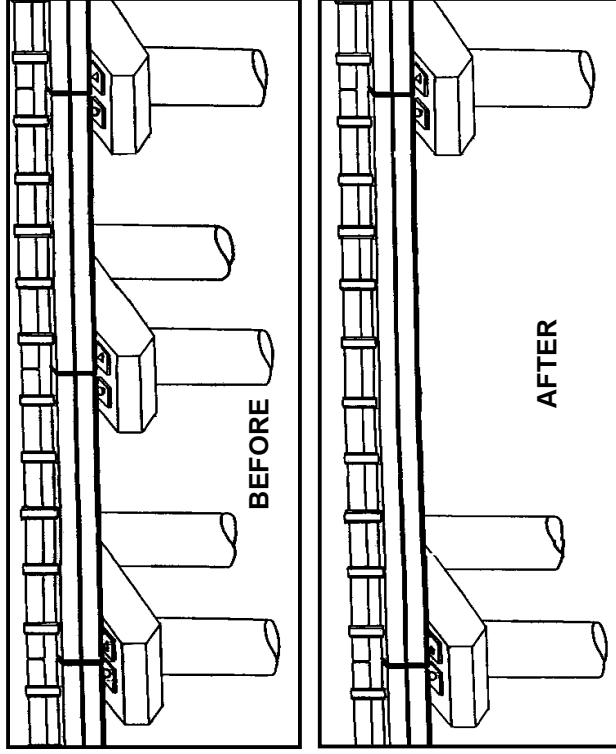

Effectiveness:

- Very effective.

Limitations:

- Careful analysis and design for post-mitigation bridge deck contraction, expansion, and steel reinforcement is needed.

Considerations:



BRIDGES

D. Cap Beam Failure

Problem: Cap beams are the parts of a bridge structure that support the girders and are supported by the piers. Cap beams can fail if they can not resist the bending caused by earthquake forces. Cracks in the cap beam are visible signs of this failure.

Mitigation Objective: Increase strength and resistance of cap beams to bending, thereby increasing the overall strength of the bridge structure.

Mitigation measures to protect bridges from cap beam failure include:

1. Prestress Cap Beams p. 83
2. Strengthen Cap Beams With Bolsters p. 84

D.1 Prestress Cap Beams

Cap beam failures often occur during earthquakes due to inadequate reinforcement. This failure results in very large cracks that can ultimately cause total collapse of the bridge. Cap beam failure can be avoided by prestressing the concrete cap beams using tendons to increase earthquake resistance and strength. Prestressing involves compressing the concrete, then tendons are anchored to end blocks. The tendons can be installed externally on the side of the beam, or internally using ducts cored through the beam.

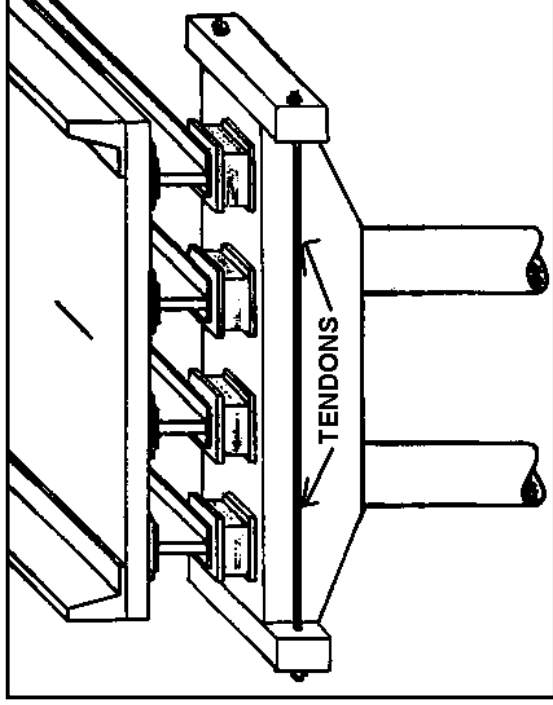

Effectiveness:

- Very effective.

Limitations:

- Tendons installed externally may be more prone to corrosion.
- Tendons installed internally can be very difficult and expensive to construct.

Considerations:



BRIDGES

D.2 Strengthen Cap Beams With Bolsters

Strengthening cap beams by adding reinforced concrete bolsters can increase beam strength. This measure will reduce the impact from vertical gravity loads while minimizing beam movement from the earthquake forces. The new bolsters are placed on both sides of the existing cap beam and connected with dowels drilled through the existing beam.

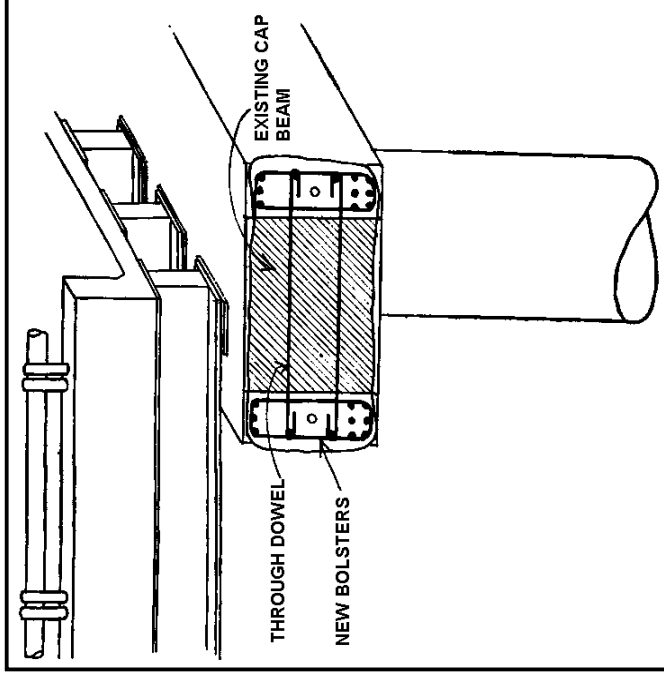

Effectiveness:

- Very effective.

Considerations:

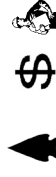

UTILITIES

Introduction

Utilities include water, wastewater, fuel, electricity, gas, and telecommunications systems. The basic components of utilities include supply and storage equipment, transmission lines, and the connections between these components. Utility components may be located above ground or underground, and rely on poles, grade level foundations, or soils for support.

Utilities commonly suffer earthquake damage for two reasons:

1. *Above ground* utility equipment, tanks, pipelines, and connections are often inadequately braced or inadequately secured to their foundation structures. Like buildings and other facilities, utilities tend to be designed for vertical gravity loads. As a result, the equipment anchorage and pipeline bracing may not be strong enough to carry the large lateral forces associated with earthquakes.
2. *Underground* utility pipelines and connections are often too weak or inflexible to withstand earthquake ground movements and differential settlements, causing them to crack or fail. Materials that are too flexible, however, also cannot handle additional displacements from earthquake forces.

Types of Damages to Utilities. Typical types of utility damage are described below:

Supply equipment. Supply equipment such as electrical transformers, pumps, or generators are typically located on grade level foundations or elevated support structures. When this equipment is not supported or anchored properly it may topple or fall from its supports during an earthquake. Supply equipment mounted on separate foundations can also be damaged by differential settlements or movements between the foundations. Porcelain components of electrical transformers are brittle and can break during an earthquake.

Utility transmission lines. Utility transmission lines include pipes with joints for water, wastewater, fuel, gas, and electrical conduits that run underground or above grade level. Damage to above ground transmission lines typically occurs along unsupported line sections when lines crack, leak, or fail. Damage to underground transmission lines usually occurs in areas of soil failure where the line sections cannot withstand soil movements or differential settlements.

Connections. Damage to connections between utility pipeline sections and/or between utility transmission lines and equipment occur where the connections can not withstand soil movements or differential settlements.

Tank structures. Tank structures may be oriented vertically, horizontally, at grade, or elevated. Tall vertical tank structures or standpipes are often damaged by a combination of the structure's reactions to ground shaking and dynamic forces generated by water sloshing inside the tank. Tank foundation supports fail and denting of thin tank wall sections often result. The most serious type of vertical tank damage occurs when the tank walls crush near the base, triggering tank leakage or collapse. Horizontal tanks are often damaged when tanks are not securely anchored to the foundations. Elevated tank structures may be damaged due to buckling of the cross braces between the tank legs.

UTILITIES



In addition to the types of damage listed above, damage to utilities can trigger secondary damages that affect the community at large. Leaking or broken utilities can cause water damage, fire or explosion. Since these systems are interconnected, a loss of one utility system (such as electrical power) can often lead to a loss of other systems.

A structural engineer may need to be consulted to identify whether certain mitigation measures are appropriate. Some measures included in this section are not appropriate for all utilities. **Be aware** that choosing the wrong measure may cause more problems than not doing any retrofit at all.

Earthquake-related damage to utilities may be caused by:

- A. *Poor Equipment Anchorage/Stability*..... p. 88
- B. *Soil Movement/Settlement*..... p. 91
- C. *Damage to Tank Structures*..... p. 96

A. Poor Equipment Anchorage/Stability

Problem: Utility equipment such as electrical transformers and generators are often not properly anchored or stabilized to carry earthquake forces and movements. As a result, such equipment can tip over or fall during an earthquake, damaging the equipment and creating additional hazards.

Mitigation Objective: Anchor or stabilize utility equipment to withstand earthquake forces and movements.

Mitigation measures to reduce damage caused by poor equipment anchorage/stability include:

- 1. Anchor Electrical Transformers p. 89
- 2. Combine Equipment on One Foundation p. 90

UTILITIES

A.1 Anchor Electrical Transformers

Ground movement during an earthquake can cause inadequately anchored, pole-mounted transformers to fall, and slab mounted transformers to slide or topple. Damage caused by the movement of these transformers can be mitigated relatively inexpensively by properly anchoring the transformers to utility poles and the equipment to foundation slabs. Connections to the transformers should be flexible enough to help isolate the stresses from other sources. Unanchored electrical and instrumentation cabinets and motor control centers should also be anchored to prevent sliding or toppling.

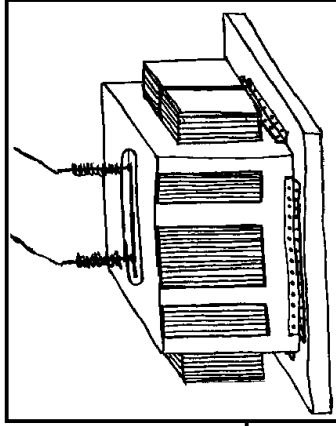

Effectiveness:

- Very effective.

A.2 Combine Equipment on One Foundation

Differential movement during an earthquake can result in the misalignment of mechanical equipment. Horizontal pumps, compressors, and other mechanical equipment that have connected motors, engines, and similar components should be mounted on a single foundation.

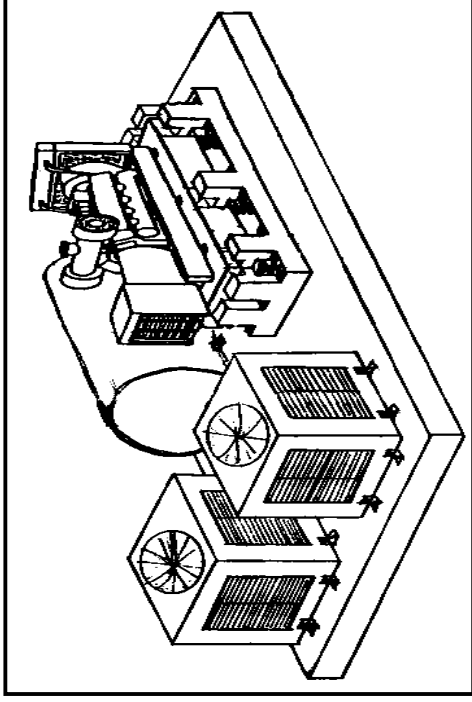

Effectiveness:

- Very effective.
- Secure equipment to foundation for maximum effectiveness.

UTILITIES

B. Soil Movement/Settlement

Problem: Underground utility transmission lines and connections are often not strong enough to withstand soil movements or differential settlement triggered by earthquakes. Utility pipelines and connections located above ground may not be properly braced against earthquake forces and movements. As a result, transmission lines and their connections can crack, leak, or fail, even damaging other facilities.

Mitigation Objective: Reinforce, restrain, or improve utility transmission lines and connections to withstand earthquake forces, soil movements and differential settlements.

Mitigation measures to reduce damage to utilities caused by soil movement/settlement include:

1. Install Expansion Joints p. 92
2. Reinforce Well Shafts or Install Submersible Pump p. 93
3. Restrain Pipes p. 94
4. Improve Pipe Materials p. 95

UTILITIES

B.1 Install Expansion Joints

During earthquakes, ground motion can cause transmission lines to leak, crack or break. **Expansion joints** can be added to allow some movement. There are a variety of expansion joint configurations and materials available, from flexible, single-layer joints to complex, multi-layer composite constructions. Expansion joints are installed as flexible connections at various points along duct and pipe systems.

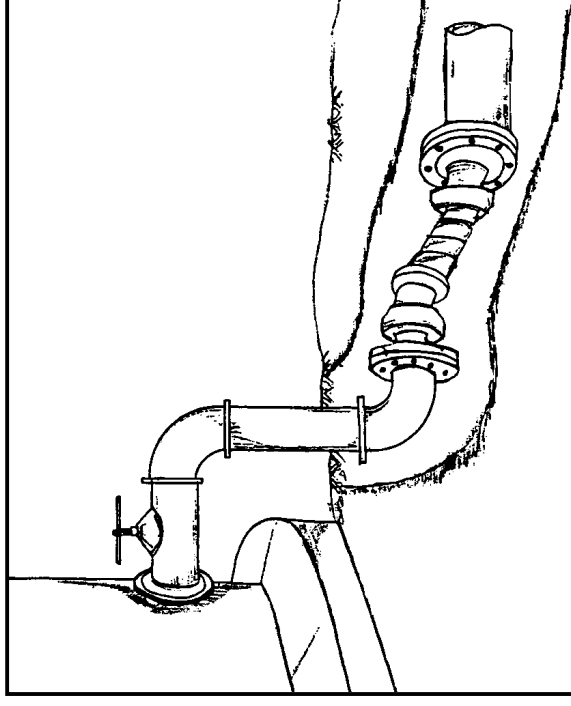

Effectiveness:

- Somewhat to very effective.

Limitations:

- Qualified professionals should design and install expansion joints.

Considerations:



B.2 Reinforce Well Shaft or Install Submersible Pump

Groundwater well casings, long shafts for pumps, and other well equipment can be damaged from ground movement. Two measures to reduce damage are: 1) Install a heavy well casing to protect the shaft and the pump from ground movement; and 2) Install a submersible pump as it does not incorporate a long shaft and so is not vulnerable to shaft damage. In areas with a risk for liquefaction, install a larger outside casing down to the liquefiable soil layer to protect equipment.

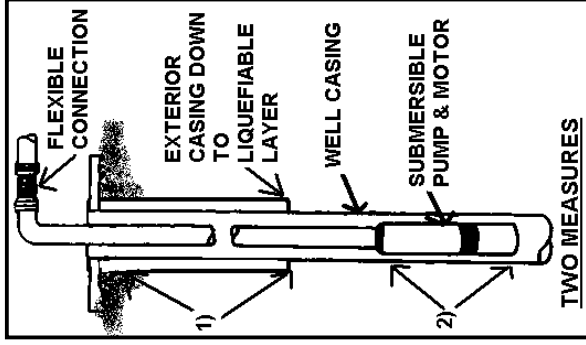
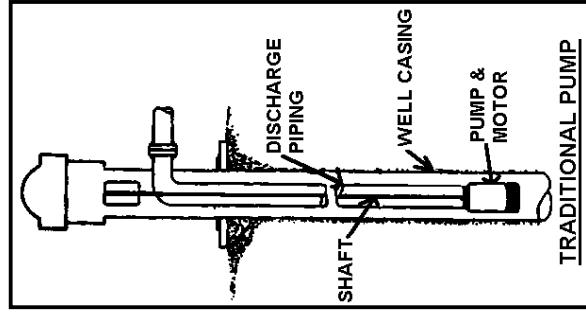

Effectiveness:

- Somewhat to very effective, depending on displacement.
- Allow space for movement between the casing and equipment slab to increase effectiveness.
- Install a flexible connection between the casing and discharge piping to increase effectiveness (See p. 57).

Limitations:

- Pumps constructed of steel are less prone to damage than cast iron pumps.
- Consider using well screens rather than slotted casing to reduce damage to equipment from pumping sand.

B.3 Restrain Pipes

During an earthquake, soil movement along underground and above-ground pipelines can cause pipes to pull apart or fracture. Restraining rods installed loosely with rubber gaskets on existing pipes at bell and spigot joints can allow for extension, compression, and joint rotation. Replace pipe with flexible joint pipe, or ball and socket pipe with restraining rings. These pipes provide varying degrees of joint freedom while restraining the joints from separating.

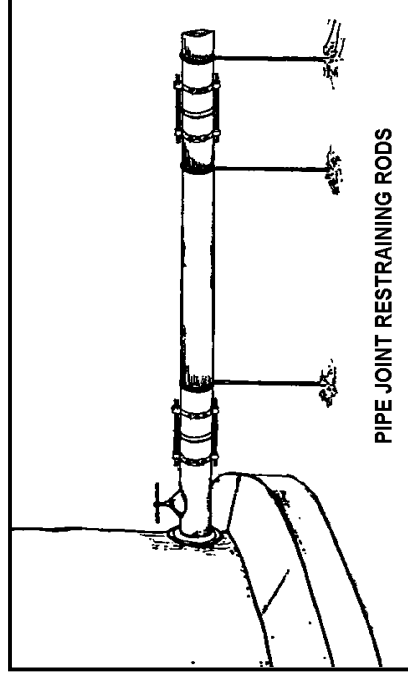
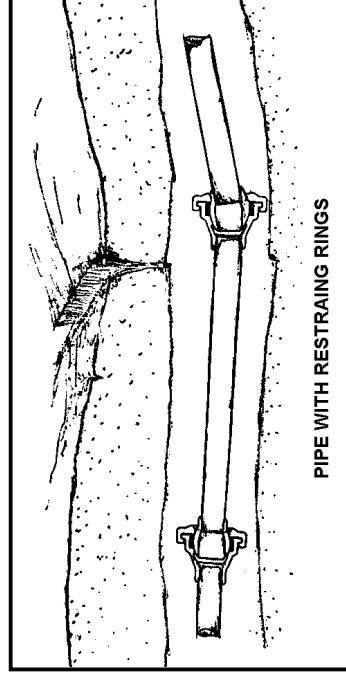

Effectiveness:

- Very effective.

Limitations:

- May not be cost effective for undamaged underground lines.

UTILITIES

B.4 Improve Pipe Materials

The performance of underground piping in earthquakes is largely dependent upon the construction material for the pipe. Pipes made of brittle materials, such as cast iron, are particularly vulnerable to breakage during an earthquake. Replacement of pipe made of brittle materials with pipe made of more flexible, ductile materials like steel, ductile iron, copper, and some plastics can mitigate pipe damage from an earthquake.

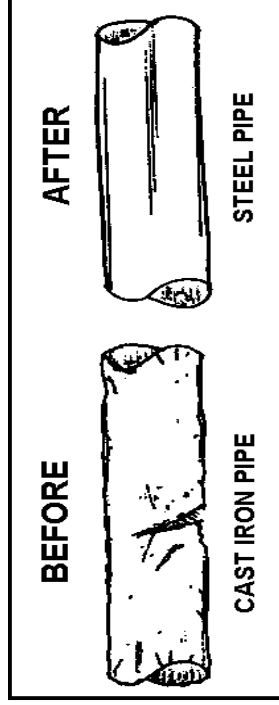

Effectiveness:

- Somewhat to very effective, depending on ground displacement.
- Strengthening ductile pipe by increasing the pipe wall thickness can also improve the viability of the pipeline.
- Corrosion protection measures for buried pipelines in corrosive soils can maintain the pipe strength.

Limitations:

- May not be cost effective for undamaged underground lines.

UTILITIES

C. Damage to Tank Structures

Problem: Vertical tank structures or standpipes may be improperly anchored to their foundation. Tank wall sections may not be adequate to handle ground movements and the dynamic forces generated by water sloshing inside the tank. Horizontal tank structures may not be sufficiently anchored to their foundations to withstand earthquake forces, and elevated tank structures may not be adequately braced against lateral earthquake forces and movements. As a result, tank structures can move, leak, or collapse during an earthquake, destroying the tanks and creating additional hazards.

Mitigation Objective: Anchor or improve tank structures to withstand earthquake forces and movements.

Mitigation measures to reduce damage to tank structures include:

1. Anchor Tank Structures at Base p. 97
2. Install Friction Dampers on Elevated Tanks p. 98
3. Stiffen Vertical Tank Walls p. 99

C.1 Anchor Tank Structures at Base

Anchors installed at a tank base can reduce damage from earth movement.

For vertical tanks, anchor systems can be: 1) Composed of metal straps welded to tank and embedded in a concrete footing; and 2) Consist of vertical anchor bolts connected with chair anchors into the foundation.

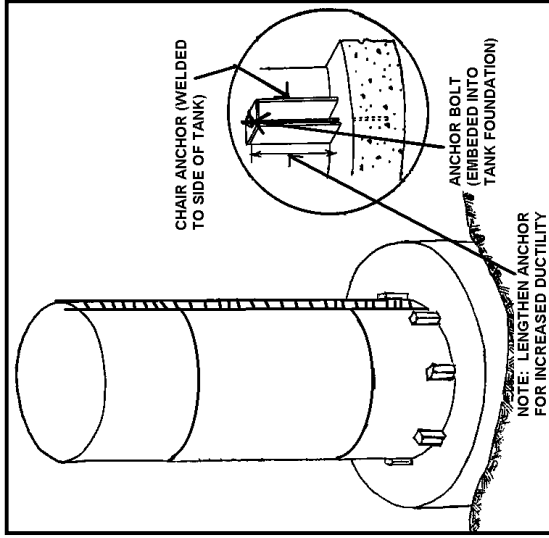

Large horizontal tanks, both above and below ground, should also be securely supported and anchored. Horizontal tanks should have saddles or other supports to provide longitudinal support.

Effectiveness:

- Very effective in reducing tank damage.
- Install flexible connections to reduce pipe related damage.

Limitations:

- Foundations need to be sufficient to support anchoring.

Considerations:



UTILITIES

C.2 Install Friction Dampers on Elevated Tanks

Large, elevated tank structures are commonly damaged by ground movement. Friction dampers can be installed to help absorb tank movements and increase seismic resistance. The dampers are designed to slip at a predetermined load to reduce forces imposed on the tank and can be integrated into the **cross bracing** supporting the tank.

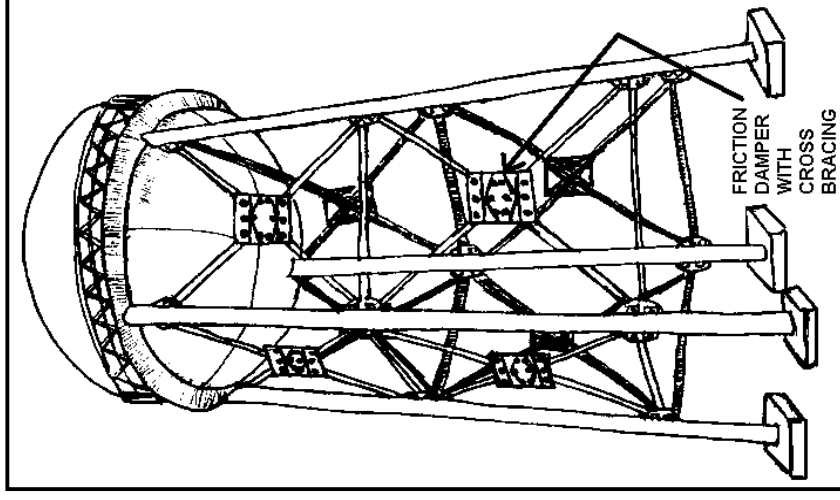

Effectiveness:

- Very effective in reducing tank damage.
- Install flexible connections to reduce pipe related damage.
- Effectiveness depends on analysis of existing tank behavior and location of dampers.

Considerations:



C.3 Stiffen Vertical Tank Walls

Thin tank wall sections can buckle due to seismic forces and the dynamic forces of water sloshing inside the tank. To reduce the risk of future earthquake damage, damaged tank wall sections can be stiffened during repairs with steel beams that are welded to the inside of the tank.

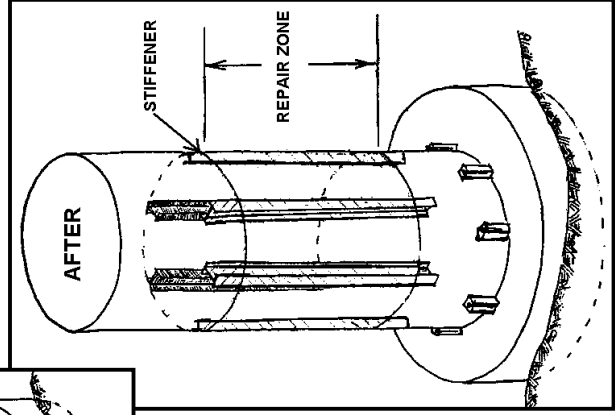
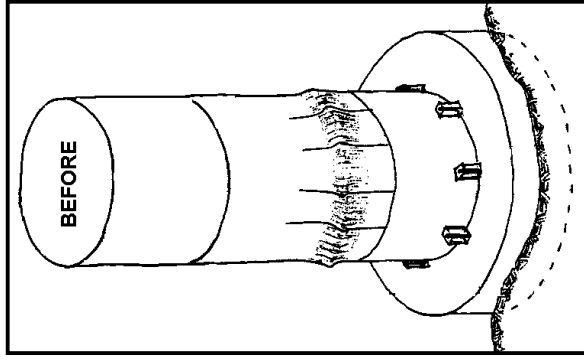

Effectiveness:

- Somewhat effective.

Limitations:

- Repair of tank wall requires emptying, disinfecting, and relining the tank.

Considerations:



UTILITIES

APPENDIX A

REGULATIONS AND CONSIDERATIONS

Significant regulations and issues, identified by symbols that should be considered when developing one of the projects identified in this Handbook are identified below. It is solely the project proponent's responsibility to ensure that all applicable codes and standards are met, regardless if they are identified in this Handbook.



National Environmental Policy Act (NEPA)

All federal agencies must consider the effects of federally-funded projects upon the environment as required by NEPA. Actions identified by this symbol may have an impact on the environment and may require further investigation to determine the extent of any impacts.



National Historic Preservation Act (NHPA)

NHPA strives to protect our nation's heritage, and requires the review of any project that affects a structure 50 years or older that may be on (or eligible for) the Federal Register of Historic Places, or that affects a site which may contain artifacts of archaeological or cultural significance. For any action identified by this symbol, FEMA may need to consult with the State or Tribal Historic Preservation Office to determine whether any additional action or mitigation is necessary.



Project May be Cost-Prohibitive

The cost of actions identified by this symbol may be prohibitively expensive.



Maintenance Required to Maintain Effectiveness

Actions identified by this symbol may require significant and/or continuous maintenance.



Professional Engineer Required for Design

An engineer should be consulted or hired to develop and/or approve the actions identified by this symbol.



Structure's Aesthetics Could be Impacted

Actions identified by this symbol may affect the structure's appearance and/or aesthetic value.

APPENDICES

APPENDIX B

GLOSSARY TERMS and MITIGATION KEYWORD INDEX [Keywords are underlined]

Anchorage. The complete assemblage of members and parts, designed to hold in correct position a part of a structure. pp. 1, 31, 32, 37, 42, 49, 85

Anchor sill plate. pp. 8, 9, 10, 17

Bearing seats. A horizontal surface which the bearings are placed upon and which support the ends of a bridge span. p. 78

Bolsters. Reinforced concrete elements or member used to support a pier cap bearing or the abutment bridge seat, and which increases the strength of the cap beam. p. 84

Cable restrainers. Cables used to tie bridge girders between adjacent spans. pp. 75, 76

Cap beam. The part of a bridge that sits on top of the columns and supports the span. pp. 68, 76, 82

Carbon fiber wrap/sheets. Thread-like strands of pure carbon bound in a plastic resin matrix to form a strong reinforcing material. pp. 24, 26, 68

Cement plaster (stucco). Material that provides a durable cement-based finish on residential and other low-rise construction. p. 38

Chord. A continuous steel member used to tie floor and/or roof systems to the load bearing walls of a building. p. 14

Compression struts. Structural support members used to sustain compression and provide support. p. 43

Corbel. A brick, block, or bracket that projects from the face of a wall and supports an overhanging member. pp. 31, 35

Cornice. A horizontal molded projection that crowns or completes a building or wall. pp. 31, 35

Cripple wall. A short stud wall that extends from the base of a crawlspace foundation to carry the floor joists. pp. 10, 17

Cross bracing. Horizontal or diagonal elements between vertical supports used to provide lateral bracing of structures. pp. 11, 20, 29, 98

Crosswalls. Walls designed to absorb energy and limit displacements of long walls due to earthquakes. pp. 8, 9, 22

Dampen. To restrain or deaden vibration. p. 28

Dampers. Commonly called fluid viscous dampers, they act as shock absorbers by absorbing some of an earthquake's ground movement. pp. 9, 29, 99

Diaphragm. Floor and/or roof deck systems that carry lateral forces across the building to supporting structural elements. pp. 1, 5, 12, 77

Ductility. The property of a material to absorb large inelastic deformations before failing. p. 4

Epoxy anchor. A threaded rod inserted into a drilled hole filled with epoxy or another chemical resin to secure the rod. pp. 25, 35

Epoxy grout. A thin mortar used to fill cracks and crevices in concrete or masonry. p. 19

Expansion joint. For bridges and other structures, it is a joint between two parts of a structure that allows for expansion of both parts due to temperature changes. For utilities, such as pipelines, it is a flexible connector that allows for movement during an earthquake without breaking. pp. 81, 92

Girder. Steel, wood, or reinforced concrete beam used as a main horizontal support in a building or bridge. pp. 76, 77, 78, 81, 82

Inelastic deformation. Occurs when an element deforms as force is applied, but does not return to its original shape after the force is removed. p. 4

Isolation bearings. Bearings in buildings or bridges that absorb lateral movements and isolate them from the rest of the structure, reducing the impact to the structure and assisting it to move as a unit. pp. 28, 80

Lock-up device. A piece of equipment connecting bridge spans that allows for normal expansion and contraction but

increases structural integrity by 'locking up' when the structure is subjected to seismic forces. p. 79

Parapet. A wall placed at the edge of a roof to create a firebreak between buildings and prevent people from falling. pp. 9, 31, 34

Pedestal. An architectural support or base for a column. p. 46

Prestress. To strengthen concrete by compressing it so it will counteract tension forces resulting from earthquakes. p. 83

Reinforced concrete. Concrete in which steel bars or wires are embedded to increase the strength of concrete in tension, shear, and bending. pp. 4, 8, 9, 12, 34, 76, 84,

Reinforced masonry. Cast or formed bricks or blocks in which steel bars or wires are embedded. pp. 1, 4, 7, 12, 18, 19, 24, 25, 30, 31, 45

Seismic forces. Forces created by ground movement during an earthquake. pp. 11, 38, 50, 69, 75, 99

Shear. Stress in which opposing forces act on an object, causing two parts or layers to slide against each other. pp. 3, 4, 15, 66, 70, 71, 73, 75

Shear anchors. Metal rods with threaded ends that are used to prevent sliding between the floor/roof systems and walls of a building. pp. 12, 14, 18, 19, 34

Shear blocks. Reinforced concrete blocks installed on the cap beams of bridges to prevent girders from moving sideways at their bearings. pp. 75, 76

Shear walls. Vertical walls made from reinforced concrete, reinforced masonry or wood stiffen buildings and help structures resist sideways earthquake forces. pp. 5, 8

Shotcrete. Consists of concrete that can be sprayed on specially designed walls and other surfaces. pp. 8, 25, 34, 38

Simply supported span. A span that must be supported on both ends to prevent collapse. p. 81

Snubbers. Devices that limit displacements of vibrating equipment during earthquakes to reduce or prevent damage. p. 50

Soft story condition. A floor level that has stiffness significantly less than the story above it, such as buildings with large foyers or open spaces on the first floor. pp. 20, 21

Steel jackets. A steel casing that is welded or bolted around a concrete column to increase strength. pp. 68, 69

Substructure. The foundation elements that support the building or bridge. p. 65

Superstructure. The parts of a building or bridge above the foundation. p. 75

Tendon. A high-strength steel cable used to prestress or connect structural elements. p. 83

Tension ties. Steel anchor bolts used to strengthen connections between the roof or floor and the walls. pp. 12, 14, 18, 19, 34

Unseating. To dislodge an element from the bearing or member supporting it. p. 76

Vibration isolator. A device, such as a shock absorber or spring, that prevents transfer of vibrations from one element to another. pp. 28, 50

APPENDIX C

ACRONYMS

CFR	Code of Federal Regulations
ESA	Endangered Species Act
FEMA	Federal Emergency Management Agency
HAZMIT	Hazard Mitigation
HMGF	Hazard Mitigation Grant Program
NEPA	National Environmental Policy Act
NFIP	National Flood Insurance Program
NHPA	National Historic Preservation Act
PA	Public Assistance
PL	Public Law
PL 93-288	Robert T. Stafford Disaster Relief and Emergency Assistance Act

APPENDIX D

REFERENCES

- A Guide for Water Utilities: Minimizing Earthquake Damage.* American Water Works Association: Denver, Colorado (1994).
- Abatement of Seismic Hazards to Lifelines: Proceedings of a Workshop on Development of an Action Plan Volume 1.* FEMA Publ. 135. Developed by the Building Seismic Safety Council for FEMA: Washington, DC (1987).
- Abatement of Seismic Hazards to Lifelines: An Action Plan.* Developed by the Building Seismic Safety Council for FEMA: Washington, DC. (1987).
- Analytical evaluation of retrofit strategies for multi-column bridges,* by Cofer, McClean & Zhang. Technical report for Research Project T9902-11, by U.S. Department of Transportation, Federal Highway Administration, Washington State Department of Transportation, Washington State Transportation Commission, Planning and Programming Service Center: Olympia, Washington (1997).
- ATC-25: Seismic Vulnerability and Impact of Disruption of Lifelines in the Conterminous United States.* Developed by the Applied Technology Council for FEMA: Washington, DC (1991).
- Critical Issues and State-of-the-Art in Lifeline Earthquake Engineering.* Schiff and Buckle. ASCE National Convention Proceedings, San Diego, October 1995. American Society of Civil Engineers: New York, NY (1995).
- Design Guidelines for Assessment Retrofit and Repair of Bridges for Seismic Performance, Report No. SSRP-92/01.* A report to the National Institute of Standards & Technology under Contract # 50BNB1C6525. Department of Applied Mechanics & Engineering Sciences, University of California San Diego: LaJolla, California (1992).
- Earthquake Hazard Mitigation for Utility Lifeline Systems.* Emergency Management Institute. FEMA: Washington, DC (1992).

Earthquake Resistant Construction of Gas and Liquid Fuel Pipeline Systems Serving, or Regulated by, the Federal Government. Developed by the Applied Technology Council for FEMA: Washington, DC (1992).

Glossary of Some Common Terms in Seismology. National Earthquake Information Center. World Data Center for Seismology, Denver, Colorado. Internet: www.neic.cr.usgs.gov.

Ground Improvement, Reinforcement, & Grouting. International Society for Soil Mechanics & Geotechnical Engineering. International Technology Transfer Center for Ground Improvement Geosystems Polytechnic University: Brooklyn, NY. Internet: <http://tc17.poly.edu/>

Guidelines for Evaluation & Mitigation of Seismic Hazards in California, Chapter 6. California Division of Mines and Geology. Special Publication 117: Internet: www.consrv.ca.gov/dmg/pubs/sp/117/chap_6.htm

"High-Tech Isolation." Lee, Peter L. et al, 2001. American Society of Civil Engineers. Reston, Virginia. *Civil Engineering*, May 2001.

"Seismic Retrofit of Steel Bridges." Malik, A.H. *Modern Steel Construction.* American Institute of Steel Construction: Chicago, IL (1997).

Natural Hazard Mitigation: Recasting Disaster Policy & Planning. Godschalk, Beatley, Berke, Brower and Kaiser. Island Press: Washington, DC (1999).

Nature of Ground Motion and Its Effect on Buildings, The. National Information Service for Earthquake Engineering (NISEE). University of California: Berkeley, CA (1982).

NEHRP Handbook of Techniques for the Seismic Rehabilitation of Existing Buildings. FEMA Publ. 172. Prepared by Building Seismic Safety Council: Washington, DC (1992).

Reducing the Risks of Nonstructural Earthquake Damage: A Practical Guide. FEMA Publ. 74. Prepared by Wiss, Janey, Elstner Associates, Inc. for FEMA: Washington, DC (1994).

Screening Guide for Rapid Assessment of Liquefaction Hazard at Highway Bridge Sites. Research conducted at Brigham Young University, supported by Federal Highway Administration Contract # DTFH61-92-C-00106. Multidisciplinary Center for Earthquake Engineering Research: Buffalo, NY (1998).

Seismic Design and Retrofit of Bridges. 1996. Priestley, Seible & Calvi. Wiley-Interscience, John Wiley & Sons, Inc.: New York, NY (1996).

Seismic Retrofit Measures for Highway Bridges. Robinson, Longinow & Albert. Report. Engineering Research Division, IIT Research Institute: Chicago, IL (1979).

Seismic Retrofitting Alternatives for San Francisco's Unreinforced Masonry Buildings: Estimates of Construction Costs and Seismic Damage. Report. Rutherford & Chekene Consulting Engineers: San Francisco, CA (1990).

Utah Guide for the Seismic Improvement of Unreinforced Masonry Dwellings. Utah Department of Public Safety, Division of Comprehensive Emergency Management: Salt Lake City, UT. Internet: www.cem.state.ut.us/

APPENDIX E

LIST OF CONTRIBUTORS

Jean Chaney, Recovery Branch Chief

Lois Lopez – Public Assistance

Angela Aubuchon – Public Assistance

Toni Aubuchon – Public Assistance

Richal Smith – Public Assistance

Rod Van Mechelen – Public Assistance

Phil Carpenter – Hazard Mitigation

Dayna Bailey – Technical Assistance Contractor

Jay Concepcion – Technical Assistance Contractor

Edward Federico – Technical Assistance Contractor

Pat Quinn – Technical Assistance Contractor

John Squerciati – Technical Assistance Contractor

Anahid Kristina Tokes – Technical Assistance Contractor

APPENDICES